

ARMY OF THE EBON FOREST TROOPS AND TACTICS

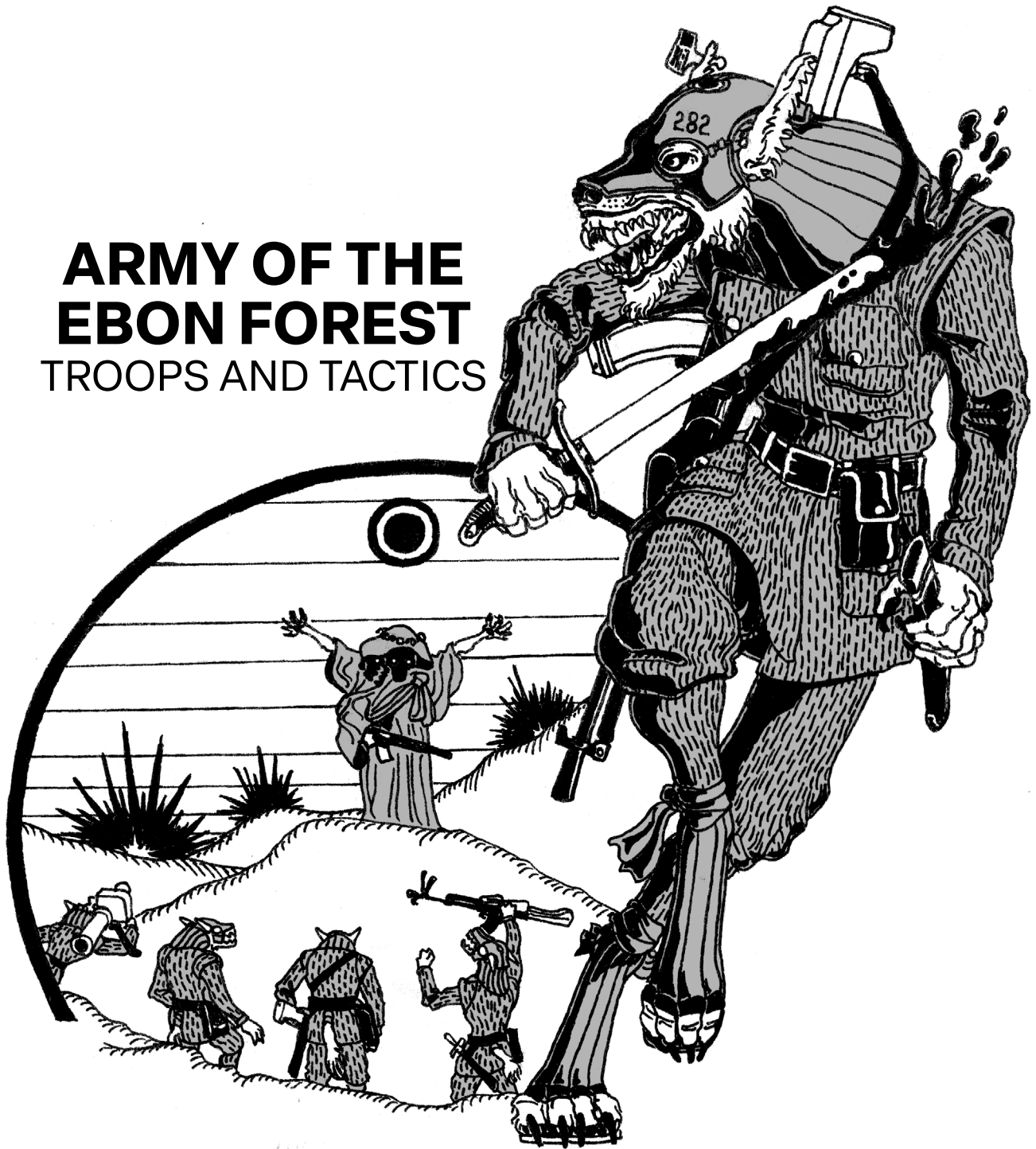

DISTRIBUTION RESTRICTION: This publication contains technical, operational, or strategic information that is for official government use only. Distribution thereof is limited to government agencies of the Intermarine Federation or licensed contractors. Special use releases of this publication must be requested from Reception & Disposal, Drekfort Military Development Center, Langport, Vansa, PO 32001.

No. 1540	<i>HIJMEIER BASIS</i>
Naam	R IRVING
Vervaldatum	01-30-81
Retourdatum	09-03-81
*Gelieve terug te geven indien geleend of gevonden.	



HEADQUARTERS
DREKFORT M.D.C.
Langport, Vansa, 03/10/85

Army of the Ebon Forest: *Troops and Tactics*

Preface

This field manual is part of FM series 100-X-8X. The other volumes in this series are FM 100-1-8X (The Federal States-Army: Troops and Tactics), FM 100-3-8X (The New Rygolic Host: Troops and Tactics), and FM 100-4-8X (Atom Barons of Santagria: Troops and Tactics). Each volume in the series describes the range of troop types and characteristics of an opposing force to the Federal States-Army.

This document, FM 100-2-8X, describes the known elements of the Army of the Ebon Forest. Used together, they form a thorough reference on any challenges the F.S-A. may expect to face, as well as its own strengths and weaknesses in comparison to them.

This manual represents the definitive (condensed) source of unclassified information on luparic ground and air forces: their abilities, strengths, weaknesses, and general availability to a commander. The Main Threats Directorate at the Drekfort Military Development Center, Langport, Vansa, updates these manuals periodically to provide the most current unclassified information available.

* This manual supersedes FM 100-2-8X Edition 0.8, 08/24/83.

Contents

CHAPTER	1. Overview	1 -1
	2. TACOMs	2 -1
	3. Infantry	3 -1
	Line Squads	3 -2
	Weapon Teams	3 -8
	Special	3 -12
	4. Vehicles & Towed Guns	4 -1
	Logistics	4 -2
	Personnel Carriers	4 -3
	Armor	4 -6
	Fire Support	4 -7
	Special	4 -17
	5. Aircraft	5 -1
	Helicopters	5 -2
	Planes	5 -5
	6. Emplacements	6 -1
	7. Scenario Units	7 -1
APPENDIX	A. Army Special Rules	A -1
	B. Army Special Missions	B -1
	C. Building an Army List	C -1
	D. Quick Unit Reference	D -1
	E. Painting Guide	E -1

CHAPTER 1 OVERVIEW

The Kingdom of the Ebon Forest is a totalitarian state, helmed by a Regent and his council in the name of its deceased monarch and founder, the Wolf-King. It occupies a peninsula in the northwest of Oid bordering the Intermarine Federation to the east and the Rygolic Petty States to the south, contesting the waters of the Sea of Lights with the Giant Kingdoms to its west.

The Army of the Ebon Forest (A.E.F.) constitutes the royal regular forces of the Ebon Forest, pledged to the service of their skeletal Wolf-King. The Regency Council at the head of the A.E.F. presents their military as a powerful modern force equal to our own States-Army (see **FM 100-1-8X**). In truth, it is an under-equipped and unpopular institution: the polar opposite of the F.S.A. in every respect.

Do not mistake poverty for martial incompetence. A combination of super-human resilience and clever tactics make the A.E.F. a remarkably stout defensive force in their home terrain and the most pressing threat to Inter-marine liberty in the present day.

The A.E.F. is composed wholly of the native denizens of the Ebon Forest: the lupar. Remember the following rules of thumb when operating against any lupar troops:

1. Remain downwind of enemy positions when possible. Maintain sound discipline.
2. Anticipate enemy action to be most frequent at night. Post guards with night-vision equipment or starlight scopes.
3. Establish overlapping sectors of fire and final protective firing lines for every new position.
4. Do not attempt to take prisoners without appropriate restraints and at least three guards. Prioritize by rank.

FACTIONAL STRENGTH:

Superlative mobile infantry.

FACTIONAL QUIRK:

Many units are multi-purpose.

FACTIONAL WEAKNESS:

Poor fire support vehicles and tanks.



PREFECTURES AND STRATEGIC CITIES OF THE EBON FOREST

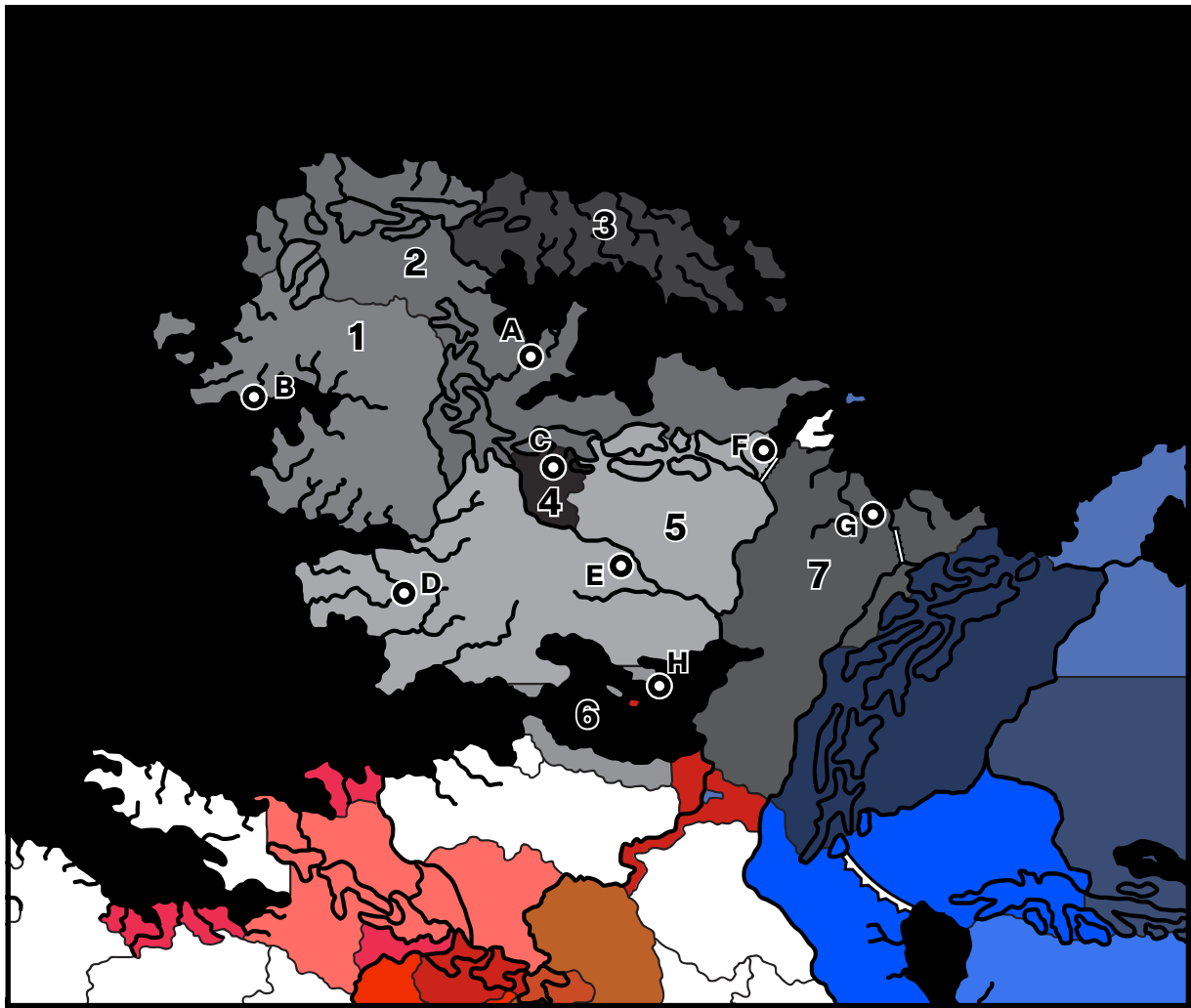

PREFECTURES:

- | | | |
|------------------------------|-------------|--------------|
| 1 - Koskal | 2 - Toskona | 3 - Olariuma |
| 4 - Traipse du Roi | 5 - Abhais | 6 - Etroique |
| 7 - Gathering of the Tribes* | | |

STRATEGIC CITIES:

- | | | |
|-----------------|-------------------|-----------------|
| A - Vuno | B - Tòl | C - Carcalhight |
| D - Lotte-Avoy | E - Chlodach Bain | F - Baselard |
| G - Plinth Mons | H - Sanc-du-Mer | |

* Indigenous name varies. Consult FM 2-10-19 *"Borderland Culture of the Ebon Forest"* for a full list of names and alternative spellings.

CHAPTER 2 TACOMS

Ebon Forest commanders prefer to coordinate operations dismounted and in person. They have no equivalent to a dedicated command post vehicle, unlike the F.S-A.'s Appomattox. When not occupying camouflaged posts or hardened bunkers, they are leading their troops in combat. A combination of a relatively high turnover rate and the A.E.F.'s meritocratic attitude means that rank is only loosely important for command; a company chief might find himself directing a much larger or smaller force than what his written manuals dictate.

Often, command is supplanted or taken over by personnel outside the regular army structure. The Regent's interior troops and rooters-out of savagery, the notorious Internal Security, are authorized to subordinate royal forces on an as-necessary basis. To be "assisted" by I.S. is never a promising sign for a lupar officer's career. On rarer occasions, waykeepers (the Ebon Forest's traditional order of ascetic warrior-priests) may attach themselves to a unit at the front. Even if they lack a formal rank, they typically become the de-facto formation command. No lupar—at least one in his right mind—would oppose their sage and fearsome judgment.

TACOMS

COMPANY CHIEF - COMMAND TEAM	0 pts / 2-2
INTERNAL SECURITY ESCORT - COMMAND SHOCK SQUAD	15 pts / 2-3
WAYKEEPER JUDGE - RELIGIOUS LEADER	20 pts / 2-4

COMPANY CHIEF



COMPANY CHIEF - 0 pts
COMMAND TEAM

Inf, H1, S24", M5", Q4, T1+/1/1, C3
Bloodlust, Brigade (4, 8"), Infiltrator,
Sense (6")

Mle. 38 .30 LMG

All, R10", A4+/5+, S1/1+, D2,
Small Arm

Mle. 44 3.5-inch RPG

Inf/Vec, R8", A4+/6+, S9/1+, D1,
 Ammo 2, *Shaped Charge, Small Arm,*
Slow Round

OtPv. 9 30-inch Machete

Inf, R0", A1+/1+, S1/1, D2, *Melee*

Stimulant-Laced Bomb, "Signal Salt"

Gnd, R6", A++/++, D1, Ammo 1,
Light Indirect (0), Radius (3"),
Rally (Salt), Small Arm

FEDERAL STATES-ARMY - DREKFORT M.D.C.

TYPE: COMMAND TEAM

REMARKS

A.E.F. company chiefs are accustomed to leading from the front, equipped in similar fashion to their subordinate infantry. Although authorized to wear officer's decorations (including sleeves, cuffs, and a black cockade), the only article of rank customarily worn in the field is their metal helmet crests.

Standard-issue to ranking officers is the "signal salt" grenade, containing olfactory identifiers and stimulants meant to direct and rally luparic troops. Company chiefs or their adjutants also receive RSP-77 backpack radio transceivers meant to work with the smaller handsets carried by subalterns.

FEDERAL STATES-ARMY - DREKFORT M.D.C.

Lupes can handle a heavy load—give 'em water and a little salt pork and they'll lug everything short of a tank on their back through the forest for the whole day. Even still, I gotta pity the guys in crests.

A light machine gun (even if it's cut-down), a machete, the same ammo load as the grunts. The whole stonking manpack radio, ear-set, and battery units. Spares for the latter. Plus the existence load: rations and supplies for a week's maneuvers and fighting. On top of all of that, pile on the weight of responsibility—you're talking a company chief here.

They don't like to share the load. I'm told some of them just flip the whole box onto their belly when they sleep. All straightened out, on a bed or cot, because curling around your MG is bad form for an officer. (Nobody told ours that last part, I guess.)

- Rayleigh Irving, Federal Intelligence

INTERNAL SECURITY ESCORT

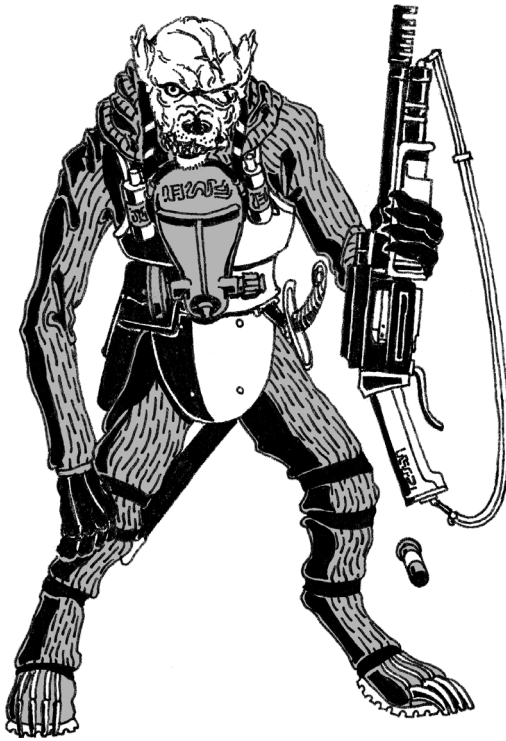

INTERNAL SECURITY ESCORT - 15 pts
COMMAND SHOCK SQUAD

Inf (S), H1, S16", M4", Q5, T2/1+/1+, C4
Assault Specialist, Brigade (3, 4"), NBC

FdcL 63 4-gauge Shotgun

Inf/Vec, R6", Small Arm

→ **4-gauge Houndshot**

A4+/4+, S1/1+, D3

→ **4-gauge Rifled Slug**

A3+/3+, S2/3, D1

OtDs. 13 Tactical Breaching Charge

Vec, R0", A1+/1+, S12/12, D1,
Ammo 2, Melee

OtPv. 9 30-inch Machete

Inf, R0", A1+/1+, S1/1, D2, Melee

Stimulant-Laced Filter, "Signal Snuff"

Inf, R0", A++/++, D1, Ammo 1,*
Discreet, Rally

**May only target self.*

FEDERAL STATES-ARMY - DREKFORT M.D.C.

TYPE: COMMAND SHOCK SQUAD

REMARKS

The Regent's notorious interior troops and state-level gendarmerie. Internal Security technically lies outside the A.E.F. structure, but they are often deployed alongside the regular troops anyways. Equipped for intense breach-and-clear operations in dense concrete longhouses, they are heavily protected from head to toe, with thick steel body armor capable of resisting full-caliber rifle fire at close quarters.

Senior I.S. officers and their bodyguard detachments are often embedded into underperforming A.E.F. formations as watchdogs for the Regency—or as more competent (and politically reliable) commanders, depending on the circumstances.

FEDERAL STATES-ARMY - DREKFORT M.D.C.

He is shaven thin and his ears and tail are clipped. If he has a scent it is obscured by that of the suit. It smells of strong chemicals and cordite. There is a little lingering blood.

He walks with straight-legged steps like a flat-faced man. Jaws are tense around him. Nobody can be trusted. He does not need to see into a man's heart to punish him. If he can prove a crime then it is the wall and the large-bore. He knows what to look for. His jaw is tight too. He worries that he will miss some.

If you are in his eye then you know why.

- Conchar Goronwy, Chasseur, 96e Infanterie

WAYKEEPER JUDGE



WAYKEEPER JUDGE - 20 pts
RELIGIOUS LEADER

Inf, H1, S24", M4", Q5, T1/1/1, C5
Amphibious, Brigade (3, 12"),
Guidance (12"), Infiltrator, Sense (8")

While this unit is alive, no unit in this army can willingly go berserk. Only Judges may call Exhortation support missions.

Mle. 32 .30 Self-loading Rifle

All, R8", A3+/4+, S1/1+, D1,
Multi-Gun, Small Arm

Teeth & Claws

Inf, R0", A1+/1+, S1/1, D1, *Melee*

Stimulant-Laced Bomb, "Signal Salt"

Gnd, R6", A++/+++, D1, Ammo 1,
Light Indirect (0), Radius (3"),
Rally (Salt), Small Arm

FEDERAL STATES-ARMY - DREKFORT M.D.C.

TYPE: RELIGIOUS LEADER

REMARKS

Traditional, wandering religious order of legal authorities, lorekeepers, spiritual and political advisors, and the former wardens of the Ebon Forest's narrow and hazardous traderoads. Universally respected by the luparic populace. Though not formally recognized by the Regency, their activity continues unimpeded by state security forces.

Particularly old and influential waykeepers, known as "judges", sometimes assume de-facto command over regular army units. Taught their mysteries by experience, and often possessed of numerous mouths and hands for radio transceivers, they make for exceptionally skilled commanders.

FEDERAL STATES-ARMY - DREKFORT M.D.C.

They are there in the deep woods. They do not touch the railroads but they keep the old trails clear. They watch. Travelers are set upon still by the feral men in the night. The waykeepers deliver them from this evil. They know that play better than those who perform it now in the cities. They have been all of its actors.

The old judges would once communicate by proxy. They belonged to the forest even if they denied it its morsels. Lesser men of the robes would come to the cities in their stead. Now they show themselves before columns of the Regent's men and assume command without dispute.

What words are said in the dark?

- Conchar Goronwy, Chasseur, 96e Infanterie

CHAPTER 3 INFANTRY

The core of the A.E.F. is and always will be its proud infantry. The lupar are perhaps the most perfectly-suited race for the job: bloodthirsty, fast, strong and tough, with extremely keen senses and instinctual small-unit coordination. It helps that small arms and man-portable heavy weapons are one of the few things their limited industrial basis can reliably produce en masse.

Even if lupar infantry are among the best, they are still infantry. On a battlefield crowded with heavy metal, their life expectancy on open ground is very low. They instead excel at assaulting and holding areas of dense cover and short sightlines—urban areas, forests, and broken ground. While armed with the support weapons necessary to control and attempt to cross open spaces, they are most at home in the woods.

LINE SQUADS

TERRITORIALS - MILITIA SQUAD	5 pts / 3-2
CHASSEURS - LINE SQUAD	10 pts / 3-3
WHITE GLOVES - ELITE LINE SQUAD	20 pts / 3-4
INTERNAL SECURITY - ELITE SHOCK SQUAD	20 pts / 3-5

WEAPON TEAMS

MACHINE GUN TEAM - ANTI-PERSONNEL TEAM	10 pts / 3-8
HIMA TEAM - ANTI-PERSONNEL/TANK TEAM	15 pts / 3-9
RECOILLESS RIFLE TEAM - GENERAL-PURPOSE TEAM	15 pts / 3-10
GUIDED MISSILE TEAM - ANTI-TANK/AIR TEAM	20 pts / 3-11

SPECIAL

SUBALTERN TEAM - JUNIOR COMMAND TEAM	10 pts / 3-12
MADE-TO-ORDERS - BERSERKER SQUAD	10 pts / 3-13
WAYKEEPERS - RELIGIOUS INSTRUCTORS	15 pts / 3-14
BOUNDERS - ANTI-MATERIEL/SNIPER TEAM	20 pts / 3-15

TERRITORIALS



TERRITORIALS - 5 pts

MILITIA SQUAD

Inf (S), H1, S24", M5", Q2, T1/1-/1-
Amphibious, Bloodlust, Infiltrator, Sense (6")

Mle. 32 .30 Self-loading Rifle

All, R8", A4+/4+, S1/1+, D1,
Small Arm

OtPv. 9 30-inch Machete

Inf, R0", A1+/1+, S1/1, D2, *Melee*

FEDERAL STATES-ARMY - DREKFORT M.D.C.

TYPE: MILITIA SQUAD

REMARKS

A remnant of the pre-unified Ebon Forest's complex clan organization. "Territorial" troops are the household warriors of the surviving clans, swearing fealty to their specific chieftain before the Regency. As their loyalty to the latter is dubious at best, they are not frequently sent abroad.

While experienced in scouting and close combat, their access to heavier weapons is very limited. Most of their equipment, bar various patterns of modern rifle supplied from both domestic and foreign merchants, is unchanged from their falx-bearing ancestors.

FEDERAL STATES-ARMY - DREKFORT M.D.C.

The old wounds run deep. The elder trees remember it. The young and the lost sit and listen. The boughs twist and tell them the story in the whistling of the wind.

They recount the old forest trails. Before the steel umbilicals and the heavy supply trains that roll along them. They tell of the bands of warriors now alive only in the state poets' mouths. Mail and falx and musket and eyes of burning coal. Those who fought for self and clan and served the Wolf-King in name only.

The Regent's ancestors took the clans and welded them in their bony master's name. They clothed the clans in the ways of the flat-faced men to make us stronger. Now we make war on those we once worshiped as men above us. That is the way of things. To the blue soldiers, we pretend our woods roar as one.

It is a convenience. The chieftains still vie. The cracks widen and the Regent worries over his maps.

He kills for words like these.

- Conchar Goronwy, Chasseur, 96e Infanterie

CHASSEURS



CHASSEURS - 10 pts

LINE SQUAD

Inf (S), H1, S24", M5", Q2, T1+/1/1

Bloodlust, Infiltrator, Sense (6")

Mle. 38 .30 LMG

All, R10", A4+/5+, S1/1+, D2,
Small Arm

Mle. 44 3.5-inch RPG

Inf/Vec, R8", A4+/6+, S9/1+, D1,
Ammo 4, Shaped Charge, Small Arm,
Slow Round

OtPv. 9 30-inch Machete

Inf, R0", A1+/1+, S1/1, D2, Melee

FEDERAL STATES-ARMY - DREKFORT M.D.C.

TYPE: LINE SQUAD

REMARKS

The common infantry of the Ebon Forest. Fast, bloodthirsty, and tough. Able to carry heavy combat loads due to their inhuman physiology. Their training cycle deemphasizes mechanized operations in favor of dismounted infiltration and ambushes.

Primary armament is the Mle. 38 light machine gun, issued and carried like a service rifle. Support arms include shoulder-fired RPGs and the notorious 30-inch (762mm) machete. The latter, despite the Ebon Forest's dense foliage, is not primarily intended for brush clearing.

FEDERAL STATES-ARMY - DREKFORT M.D.C.

Modèle 38 Light Machine Gun. "Mitra"

Many have slept with Mitra even though she is not beautiful. Her snout is long and she prods you in the chest when you run. She is heavy on a long march and the younger men are shaken by her bark. Their ears are not cauliflowered yet. The instructors see to that.

- Conchar Goronwy, Chasseur, 96e Infanterie

The training compound was swallowed by dense wood. Many were lost and not found. The Regent's loyal men made pains to retain us. Before they even sized me for my uniform they punched a tag into my ear. By the spoken Law—the old Law—that made me a thrall of the state. My life became a sellable thing.

- Conchar Goronwy, Chasseur, 96e Infanterie

WHITE GLOVES



TYPE: ELITE LINE SQUAD

REMARKS

Household guard infantry of the Wolf-King, and by extension the Regency Council. Their dress uniforms, including the white gloves, are worn in a slightly-modified form during their rare campaign deployments. Professionals, blooded veteran warriors, and stimulant addicts to the last man.

Equipped with a unique side-magazine automatic rifle manufactured under contract in the Rygolic Petty States (see **FM 100-3-8X**). As the showcase troops of the A.E.F. they also receive the latest and best in special support equipment. Shoulder-fired recoilless rifles and laser target designators copied from Federal examples are issued.

FEDERAL STATES-ARMY - DREKFORT M.D.C.

WHITE GLOVES - 20 pts

ELITE LINE SQUAD

Inf (S), H1, S24", M5", Q4, T1+/1/1

Bloodlust, Fearless, Sense (6")

Mle. 52F .30 Automatic Rifle

All, R8", A4+/4+, S1/1+, D2,
Small Arm

Lacra 3.5-inch Shouldered R. R.

A3+/5+, D1, Ammo 4, *Small Arm*

→ **3.5-inch Rocket-Assisted Sabot**

Vec, R20", S8/12

→ **3.5-inch HEAT**

Inf/Vec, R16", S9/1+, *Shaped Charge, Slow Round*

→ **3.5-inch Incendiary**

Inf/Vec, R16", S1+/1+,
Ignore Cover (2), Rear Attack, Slow Round

Mle. 7 Laser Designator

All, R40", A++/xx,
Designator, Discreet

Mle. 313 26-inch Side Saber

Inf, R0", A1+/1+, S1+/1+, D2, *Melee*

FEDERAL STATES-ARMY - DREKFORT M.D.C.

The Wolf-King's bones are left beneath his canopy. It has been long since a proper Speaking of the Law. His skulls have not sat on the snouts of chosen speakers for many years. His voice has not in living memory spoken through another throat before the assembled chieftains on the high rock.

The White Gloves remember this. Their honor guard is not watched in the throne room. This last custom is beyond the Regency to end. It is said that the Wolf-King speaks to them as he once did. What does he say to them with their mouths?

- Conchar Goronwy, Chasseur, 96e Infanterie

INTERNAL SECURITY



INTERNAL SECURITY - 20 pts
ELITE SHOCK SQUAD

Inf (S), H1, S16", M4", Q4, T2/1+/1+
Assault Specialist, NBC

FdcL 63 4-gauge Shotgun

Inf/Vec, R6", *Small Arm*

→ **4-gauge Houndshot**

A4+/4+, S1/1+, D3

→ **4-gauge Rifled Slug**

A3+/3+, S2/3, D1

OtDs. 13 Tactical Breaching Charge

Vec, R0", A1+/1+, S12/12, D1,
 Ammo 2, *Melee*

OtPv. 9 30-inch Machete

Inf, R0", A1+/1+, S1/1, D2, *Melee*

Stimulant-Laced Filter, "Signal Snuff"

Inf*, R0", A++/++, D1, Ammo 1,
Discreet, Rally

*May only target self.

FEDERAL STATES-ARMY - DREKFORT M.D.C.

TYPE: ELITE SHOCK SQUAD

REMARKS

The Regent's notorious interior troops and state-level gendarmerie. Internal Security technically lies outside the A.E.F. structure, but they are often deployed alongside the regular troops anyways. Equipped for intense breach-and-clear operations in dense concrete longhouses, they are heavily protected from head to toe, with thick steel body armor capable of resisting full-caliber rifle fire at close quarters.

Primary armament is a powerful 4-gauge (23mm) combat shotgun derived from those used by state prison guards. With high-pressure rifled slugs, it is even a serviceable anti-materiel weapon.

FEDERAL STATES-ARMY - DREKFORT M.D.C.

Before the Regency and the heeling of the clans there were not places like the one I grew up in. There were the palisaded oppida on the cleared mountainsides. But those were cities of transient merchants and craftsmen and not concrete-bound masses of teeth and claws. There was breathing space. Men were calmer and surer. They did not show their desires.

I sympathize with the security men. They descend into the charnel houses when they happen. Civility grows from the barrel of a gun. When it is all over they must also clean the walls and floors. That takes great restraint, even in an enclosed mask.

- Conchar Goronwy, Chasseur, 96e Infanterie

INDIVIDUAL EQUIPMENT OF THE CHASSEUR

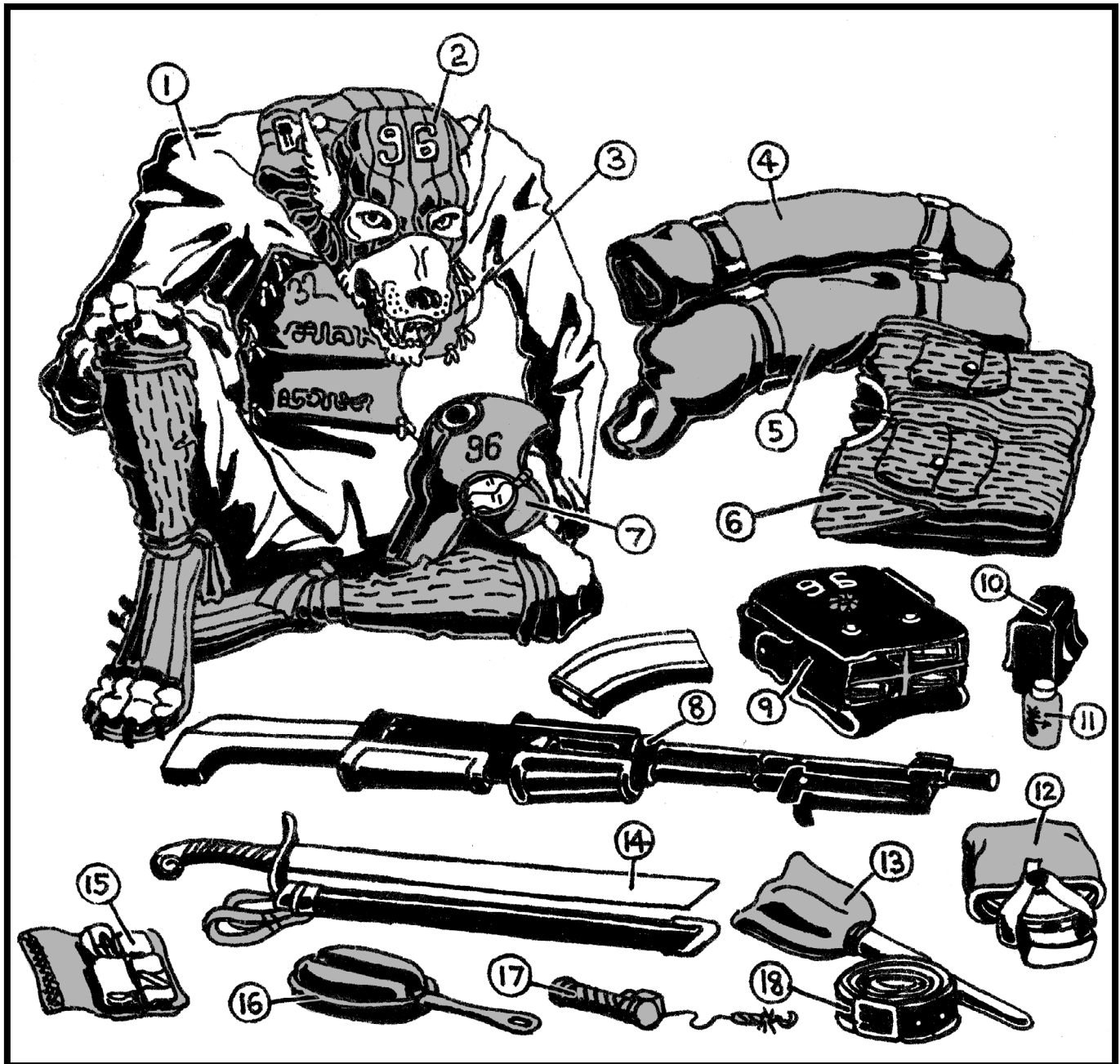

- | | | | |
|----|--|-----|--|
| 1. | Light underlayer (with plate tie points) | 10. | Grenade pouch |
| 2. | Padded coif | 11. | Tick powder |
| 3. | Ballistic plates (tied off to underlayer) | 12. | Canteen (lapping tray opened) |
| 4. | Waterproof groundsheet, rolled | 13. | Entrenching tool |
| 5. | "Tube"-type haversack | 14. | Machete and scabbard |
| 6. | Jacket (internal load straps) and trousers | 15. | First aid kit, unrolled |
| 7. | Helmet | 16. | Mess kit, handle unfolded |
| 8. | Mle. 38 "Mitra" light machine gun | 17. | Fishing tackle and line |
| 9. | Four-cell magazine pouch | 18. | Belt, with load-bearing strap hook holes |

SUPPLEMENTAL FILES

FUNNY GUYS, these territorials. If you told them to hide the crossbelts and rifles they'd step back into the dimmest primitive age. Most of them are still going into action bare-chested, flashing rings on all extremities, bound with those stupid braids and a torc like a gilded collar. They're proud of it all—proud that they're not wearing the Regent's uniform. Their chieftains remember how the Wolf-King kept his bony hands off their affairs. They know why he's not allowed to talk like he used to.

That's the thing. They can't be overt, or it's their pelt on the drying rack. But our border with the Ebon Forest's a long and broad one, and there's plenty of places where you won't find rain-flecked uniforms for kilometers—quiet sectors where people move and don't get seen.

- Rayleigh Irving, Federal Intelligence

THE SKY is pelt-gray and the stars are not yet retired. I flatten myself to the lip of a fresh shell-crater and lie on my back as if dead. At the base of the crater Odhran has upstaged me. He lies tangled and trickles blood from where the shell-splinter has bitten his skull. The scent drives me mad and I must stop my tail from drumming. I dig my nose into the mud so that I will not slip down and lap the dead man's wound.

A column nears. I watch without moving my eyes. Flat-faced soldiers with bald skin and ramrod legs pick their way past. The moons give fire to the buttons and rifle barrels and trace the well-fleshed faces' edges. They are new meat. Their eyes are not alert like jackrabbits'. Their uniforms are not creased and they smell of the iron. I wait and they pass my eyes. They recede.

There is a straggler. He looks to his fellows and to the field and slips into the crater. I hold my breath. He prods Odhran with a bayonet. He turns him belly-up and squats over the corpse and looks through each pocket in turn. I am on my haunches and his back is still turned.

I fall on him and pin the bayonet and take his neck in my jaws and pull as if tightening a cord. It is all one motion. There is no sound. I risk thirty seconds and no more. I chew what I can and I slip over the crater to the waiting darkness.

- Conchar Goronwy, Chasseur, 96e Division d'Infanterie

THEY HOLD themselves above those they kill. To the Internal Security man in his narrow visor the cannibal in the den-block is no different to the feral man in the woods who can no longer walk on two legs. Maybe he is right. Villages were not so tightly clustered a long time ago. Many walked into the woods unseen. It was said that they died. In a way that is true.

- Conchar Goronwy, Chasseur, 96e Division d'Infanterie

MACHINE GUN TEAM



MACHINE GUN TEAM - 10 pts
ANTI-PERSONNEL/MATERIEL TEAM

Inf, H1, S24", M5", Q2, T1/1-/1-
Bloodlust, Infiltrator, Sense (6")

Mle. 32 .30 Self-loading Rifle

All, R8", A4+/4+, S1/1+, D1,
Small Arm

Mtl. 19 .50 HMG

All, R20", A4+/6+, S2/3, D2,
Defensive CC

FEDERAL STATES-ARMY - DREKFORT M.D.C.

TYPE: ANTI-PERSONNEL/MATERIEL TEAM

REMARKS

Issued at the platoon level, .50 caliber (12.7mm) heavy machine guns are the most common support weapons among lupar infantry. With good range, accuracy, and firepower against both ground troops and light vehicles, HMGs add significant defensive strength to A.E.F. positions.

While lupar lack the comparative endurance of humans, their strength is superior; their HMGs are carried and deployed like our own rifle-caliber machine guns. Lupar gun crews have even been observed firing them from the hip (albeit without any particular accuracy).

FEDERAL STATES-ARMY - DREKFORT M.D.C.

Interesting how often these guys show up in dogface propaganda. You know—the kind they used to airdrop on our positions, the leaflets that now get there by way of parachute mortar shells after midnight.

By and large it's a bunch of cheap schlock drawn by state servants filling the holes in their soul with ideology. Straight-backed lupar, big guns, heroic death-struggles against the lumbering Intermarium. Little bearded gnomes in horizon blue scuttling away from the forest, back to their watery ditch-cities.

Most of it's got no grounding in reality. The state propagandists don't draw their troops snuffling around in your ribcage, even if that'd scare the shit out of some of the kids on the front. (Only the chasseurs scrawl that sort of thing, from memory.) But the machine-gunners are always pretty accurately depicted.

They really do fire from the hip when they're moving up. That open mouth is more to equalize the pressure than to roar.

- Rayleigh Irving, Federal Intelligence

HIMA TEAM

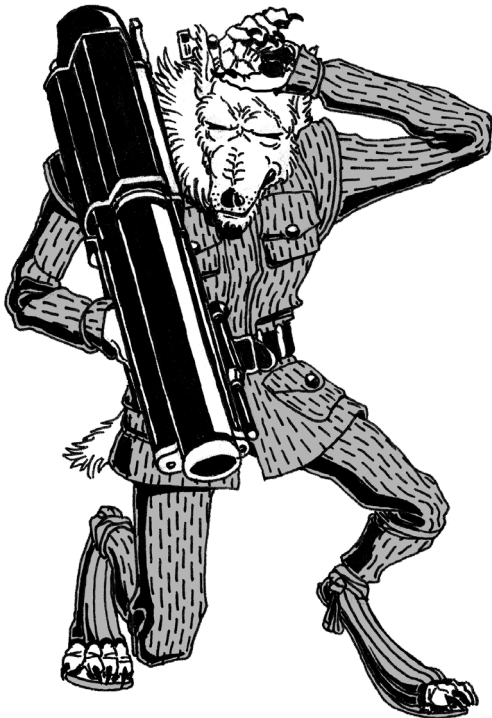

TYPE: ANTI-PERSONNEL/TANK TEAM

REMARKS

Indirect support team armed with a 3-inch (76mm) shoulder-fired light gun-mortar. The "Hima" is an advanced design despite its ubiquity in the A.E.F. inventory, featuring a sliding receiver-barrel complex that smooths out the weapon's heavy recoil impulse.

The Hima is highly versatile, functioning both as a direct-fire anti-tank system and as a light mortar. It is adept at providing fire support and screening for A.E.F. troops.

"Signal salt" rounds, issued along more standard frag and smoke shells, contain olfactory identifiers and stimulant drugs meant to direct and rally luparic troops.

FEDERAL STATES-ARMY - DREKFORT M.D.C.

HIMA TEAM - 15 pts
ANTI-PERSONNEL/TANK TEAM

Inf, H1, S24", M5", Q2, T1/1-/1-
Bloodlust, Sense (6")

Mle. 32 .30 Self-loading Rifle

All, R8", A4+/4+, S1/1+, D1,
Small Arm

Lacra-76 "Hima" 3-inch Launcher

Ammo 4

→ 3-inch Frag

Gnd, R32", A4+/xx, S[D3], D1,
*Air-Filling, Light Indirect (2),
 No CC, Radius (2")*

→ 3-inch HEAT

Inf/Vec, R8", A4+/xx, S8/1+, D1,
Shaped Charge, Slow Round

→ 3-inch Smoke

Gnd, R32", A++/xx, D2,
Light Indirect (2), No CC, Smoke (3")

→ 3-inch Signal Salt

Gnd, R32", A++/xx, D1,
*Light Indirect (2), No CC, Radius (3"),
 Rally (Salt)*

FEDERAL STATES-ARMY - DREKFORT M.D.C.

The signal salt is the first smell you are trained to recognize. It is a powerful chemical stench. You cannot mistake it for anything. I would not care for it had I not taken the Regent's ear-tag. But now it makes my mouth water.

The salt means you are close to the enemy lines. It means the assault is almost finished. The foe is almost overcome. His corpses will be available. There will be a few minutes before you are observed by a man with enough rank. Long enough.

- Conchar Goronwy, Chasseur, 96e Infanterie

RECOILLESS RIFLE TEAM



RECOILLESS RIFLE TEAM - 15 pts
GENERAL-PURPOSE TEAM

Inf, H1, S24", M5", Q2, T1/1-/1-
Bloodlust, Infiltrator, Sense (6")

Mle. 32 .30 Self-loading Rifle

All, R8", A4+/4+, S1/1+, D1,
Small Arm

TAP 20 3-inch Recoilless Rifle

Ammo 4

→ **3-inch HEAT**

Inf/Vec, R24", A4+/6+, S8/1+, D1,
No CC (Inf.), Shaped Charge,
Slow Round

→ **3-inch Canister**

Inf/Vec, R12", A4+/6+, S1/1+, D3,
Defensive CC (Inf.)

→ **3-inch Smoke**

Gnd, R24", A++/++, D1, No CC,
Smoke (3")

FEDERAL STATES-ARMY - DREKFORT M.D.C.

TYPE: GENERAL-PURPOSE TEAM

REMARKS

Recoilless rifles are reliable, versatile, and lightweight for the heavy punch that they can deliver. Compared to an equivalent enclosed-breech cannon, they stress their mounting platform considerably less; thus, they are usually shoulder-fired or mounted to tripods.

As with its Federal counterpart, the A.E.F. TAP 20 is a common direct-fire support weapon, issued across the army. Luparic physiology makes it possible for them to nimbly carry and employ these weapons in support of an attack. To that end, lupar R.R. teams are issued anti-personnel canister rounds for use at relatively short range.

FEDERAL STATES-ARMY - DREKFORT M.D.C.

It's a pocket cannon. Okay, sure, it's as tall as they are. But you haven't seen where they can hide these things. Under rotting logs, camo-netted in the bushes and twist-roots. They even put some in treetops to go after thin roof armor.

It's not exactly light, but the way dogfaces tote these things—mile after mile in the misty undergrowth—you'd swear they're just empty pasteboard tubes. All that, with ammo too, just to get at your flanks or rake you with canister.

One of these days, when this is all over, I'm hiring one for my old man's mountain inn. They like the cold and snow, and they know a thing or two about avalanche control.

- Rayleigh Irving, Federal Intelligence

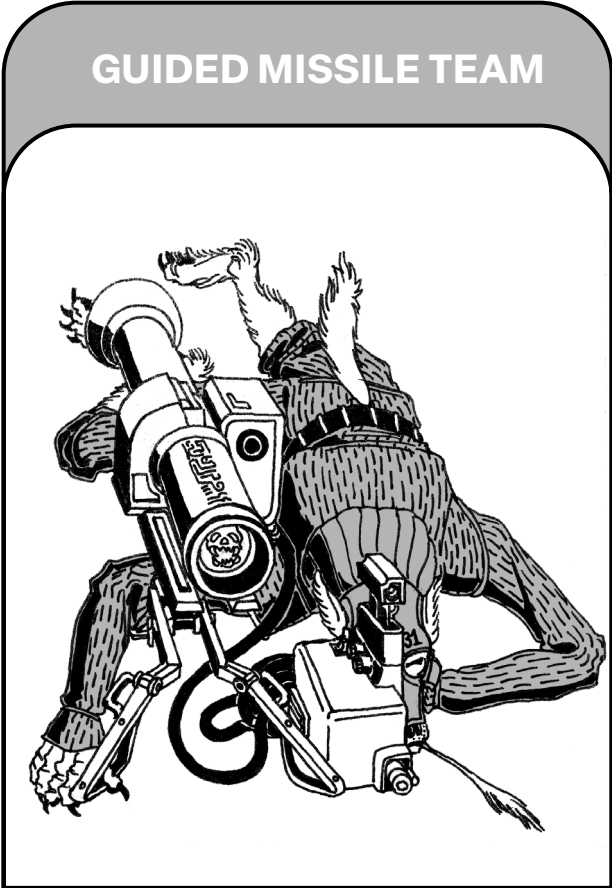

GUIDED MISSILE TEAM - 20 pts
ANTI-TANK/AIR TEAM

Inf, H1, S32", M5", Q2, T1/1-/1-
Bloodlust, Sense (6")

Mle. 32 .30 Self-loading Rifle

All, R8", A4+/4+, S1/1+, D1,
Small Arm

SD84 4.7-inch Missile Launcher

S15/2, D1, Ammo 4,
Guided Missile (2), No CC,
Shaped Charge

→ **ATGM Guidance Mode**

Vec, R6-60", A3+/xx

→ **MANPADS Guidance Mode**

Air, R60", A4+/xx

FEDERAL STATES-ARMY - DREKFORT M.D.C.

TYPE: ANTI-TANK/AIR TEAM

REMARKS

Dismounted anti-armor team equipped with the SD84 4.7-inch (120mm) guided missile complex. One of relatively few advanced electronic systems in A.E.F. use, the SD84 is issued only to first-rate units.

The SD84 is an efficient SACLOS ATGM system, able to automatically guide itself towards the illuminated crosshairs without manual corrections from the gunner.

In field service, many have been modified to permit anti-aircraft targeting. Guiding a missile by hand into a flying target is easier said than done, but the capability remains.

FEDERAL STATES-ARMY - DREKFORT M.D.C.

When my father was young there was still a group of wild men near where he lived. They were not like the feral ones who refuse to know spoken words. Neither were they like us who rooted ourselves in the gathering cities. They wandered and clothed themselves in bone and skins they had poached and waterproof groundsheets from the flat-faced traders.

They were spear hunters. They killed wild boars and burnt the meat only to remove the bristles. To spear a great boar was an act of great nerve. The boar would rage. If the spear wavered before or after the strike the boar would gore the hunter. The wound would not knit. It called for perfect calm. One kept their eyes on the boar and not the spear.

The wild men no longer show themselves.

- Conchar Goronwy, Chasseur, 96e Infanterie

SUBALTERN TEAM



TYPE: JUNIOR COMMAND TEAM

REMARKS

Subalterns are A.E.F. junior commissioned officers. Almost exclusively promoted from the ranks, they are given the right to wear an officer's tunic, crest, and black cockade. While formally billeted as platoon commanders and adjutants, they are also often used as message runners on the front line.

Standard equipment includes the RSP-10 radiotelephone handset, powered by a belt battery. For self-defense, subalterns and their attached bodyguards and orderlies are provided with the light Mle. 32 rifle also issued to weapons teams and smoke grenades. They travel light and are expected to be first-class runners.

FEDERAL STATES-ARMY - DREKFORT M.D.C.

SUBALTERN TEAM - 10 pts
JUNIOR COMMAND TEAM

Inf, H1, S24", M5", Q4, T1/1-/1-
Bloodlust, Brigade (2, 4"), Infiltrator,
Sense (6")

Mle. 32 .30 Self-loading Rifle

All, R8", A4+/4+, S1/1+, D1,
Small Arm

OtPv. 9 30-inch Machete

Inf, R0", A1+/1+, S1/1, D2, *Melee*

MdG. 341 Smoke Bomb

Gnd, R6", A++/++, D1, Ammo 1,
Light Indirect (0), Small Arm,
Smoke (2")

FEDERAL STATES-ARMY - DREKFORT M.D.C.

Some finery on the collars and a crest. A black piece of silk. With these garnishes a man is seized from the comfortable mass of the ranks and made a subaltern. He is doomed. He goes to this doom with grace.

When the shelling is thick even the grass despairs. Nothing lives for long above ground and the company chief takes to the bunkers. He speaks through buried lines and semaphores. His subalterns are his mouth at the far end of the hail. They are his eyes and ears. The men know this too.

Much is said of that little black cockade. Watered with enough shrapnel and given the campaigning sun it might grow into a cap with a rose badge. Others do not grow. They are sent home with a hole in them.

- Conchar Goronwy, Chasseur, 96e Infanterie

Funny how they wear the sleeve decorations and their bosses don't.

- Rayleigh Irving, Federal Intelligence

MADE-TO-ORDERS



TYPE: BERSERKER SQUAD

REMARKS

Lupar that succumb to their savage impulses begin to physically degenerate into larger, misshapen, asymmetric creatures with reduced sanity and emotional stability. While the Regency has sought to harness and improve this process, their scientific studies have born little fruit. The semi-feral, electrode-controlled results are dubbed "made-to-orders".

While MTOs are neither capable of nor willing to operate firearms or obey complex commands, the A.E.F. has still found employment for them as both all-terrain pack mules and shock troops: modern berserkers, reliant on claws and teeth.

FEDERAL STATES-ARMY - DREKFORT M.D.C.

MADE-TO-ORDERS - 10 pts

BERSERKER SQUAD

Inf (S), H1, S24", M5", Q6, T1+/1+/1+
Amphibious, Bloodlust, Tow (2), Sense (6")

If depleted, loses its depletion token at the end of the round after winning a close combat.

Mutated Teeth & Claws

Inf/Vec, R0", A1+/1+, S1+/1+, D3, Melee

FEDERAL STATES-ARMY - DREKFORT M.D.C.

If you know what it's like to walk wearing a ball and chain, I understand why you're in the infantry. If you know what it's like to walk on a crutch, I understand why you got out. Either way, you'll know one half of what it's like to walk like an MTO.

They spend a lot of time re-learning the basics. How to take each step, how to eat. It used to be impossible to do safely. See those shiny coils jammed into the primary head? That's the "prod brain". Keeps them quiet, massages the crunched parts of their gray matter until it stops humming. You only have to tell a lupe when to stop killing, after all.

Damage to the exposed prod brain produces profound emotional disturbance in a living berserker. Shooting the coil or shooting the handler happens more often than you think. The Heufliger Tapes and the Cencetta Reel are just textbook examples of a common autopsy; teething marks on the legs and forearms don't imply autocannibalism. They imply stress relief through habitual self-harm.

It goes deeper than appetite. They know what has been done to them.

- Johannes Veeneman, F.S-A. General Staff

WAYKEEPERS



WAYKEEPERS - 15 pts

RELIGIOUS INSTRUCTORS

Inf (S), H1, S24", M5", Q4, T1/1/1
Amphibious, Guidance (12"), Infiltrator,
Sense (8")

Mle. 32 .30 Self-loading Rifle

All, R8", A3+/4+, S1/1+, D1,
Multi-Gun, Small Arm

Teeth & Claws

Inf, R0", A1+/1+, S1/1, D1, *Melee*

Stimulant-Laced Bomb, "Signal Salt"

Gnd, R6", A++/++, D1, Ammo 1,
Light Indirect (0), Radius (3"),
Rally (Salt), Small Arm

FEDERAL STATES-ARMY - DREKFORT M.D.C.

TYPE: RELIGIOUS INSTRUCTORS

REMARKS

Traditional, wandering religious order of legal authorities, lorekeepers, spiritual and political advisors, and the former wardens of the Ebon Forest's narrow and hazardous traderoads. Universally respected by the luparic populace. Though not formally recognized by the Regency, their activity continues unimpeded by state security forces.

The presence of waykeepers in an A.E.F. unit markedly reduces observed incidences of frontline savagery or cannibalism under fire. Established waykeepers are often joined on the field by novices in their tutelage, bolstering their numbers to squad strength.

FEDERAL STATES-ARMY - DREKFORT M.D.C.

The grass-stained robes are a welcome sight to any man. A waykeeper is a man of the spirit. He knows what gnaws at those he sees. It is said even a glance is enough for a learned keeper to read a man's heart. Other things are not said when even the rumor of their coming arises. The hushed voices speak of what lies under the robes. They say the waykeeper knows his secrets by experience.

There are some that cannot help themselves unless the waykeeper is standing behind them. They take pains to clean their teeth and hide what they did. Sometimes they can hide the guilt. No man that I have broken salt pork with has willingly given into his desires while the waykeepers are near.

- Conchar Goronwy, Chasseur, 96e Infanterie

BOUNDERS



TYPE: ANTI-MATERIEL/SNIPER TEAM

REMARKS

High-caliber anti-materiel rifles, while no longer effective against tanks (their original role), are still able to penetrate light armor and destroy important components such as engines. They also turn infantry into red mists.

A.E.F. scout-snipers are issued particularly heavy weapons straddling the line between rifles and light cannons. The monstrous APX-25, firing 1-inch (25.4mm) high velocity explosive rounds from a squeeze-bore barrel, has seen significant use even against personnel, evidently in the role of a terror weapon.

FEDERAL STATES-ARMY - DREKFORT M.D.C.

BOUNDERS - 20 pts

ANTI-MATERIEL/SNIPER TEAM

Inf, H1, S32", M5", Q2, T1/1-/1-
Amphibious, Bloodlust, Infiltrator, Sense (6")

Mle. 32 .30 Self-loading Rifle

All, R8", A4+/4+, S1/1+, D1,
Small Arm

APX-25 1-inch Anti-Tank Rifle

All, R32", A3+/xx, S4/6, D1,
 Ammo 4, No CC (Inf.), *Scoped*

FEDERAL STATES-ARMY - DREKFORT M.D.C.

Customarily you'd call it overkill. You don't necessarily need a 25-millimeter round (to say nothing of the explosive filling) to pierce a flak jacket. Something rifle-caliber, maybe even suppressed, wouldn't signal to every deaf old man in the sector that there were snipers around.

See, that's the point. They're dogfaces. They know how to slip away, become a shadow of a shadow even with a big steel crutch hanging off their back. They want you to know that they're there. That one moment you're in their sights, and the next you're so much vapor.

I did get my hands on an APX-25 with some ammo a while back. The shell cap used to be tungsten, for penetrating armor. Some of them still are. But a lot are just mild steel.

Maybe they're critically short of tungsten, like what the guys upstairs say. Or maybe the assembly-line dogs already know what they're gonna be shot at.

- Rayleigh Irving, Federal Intelligence





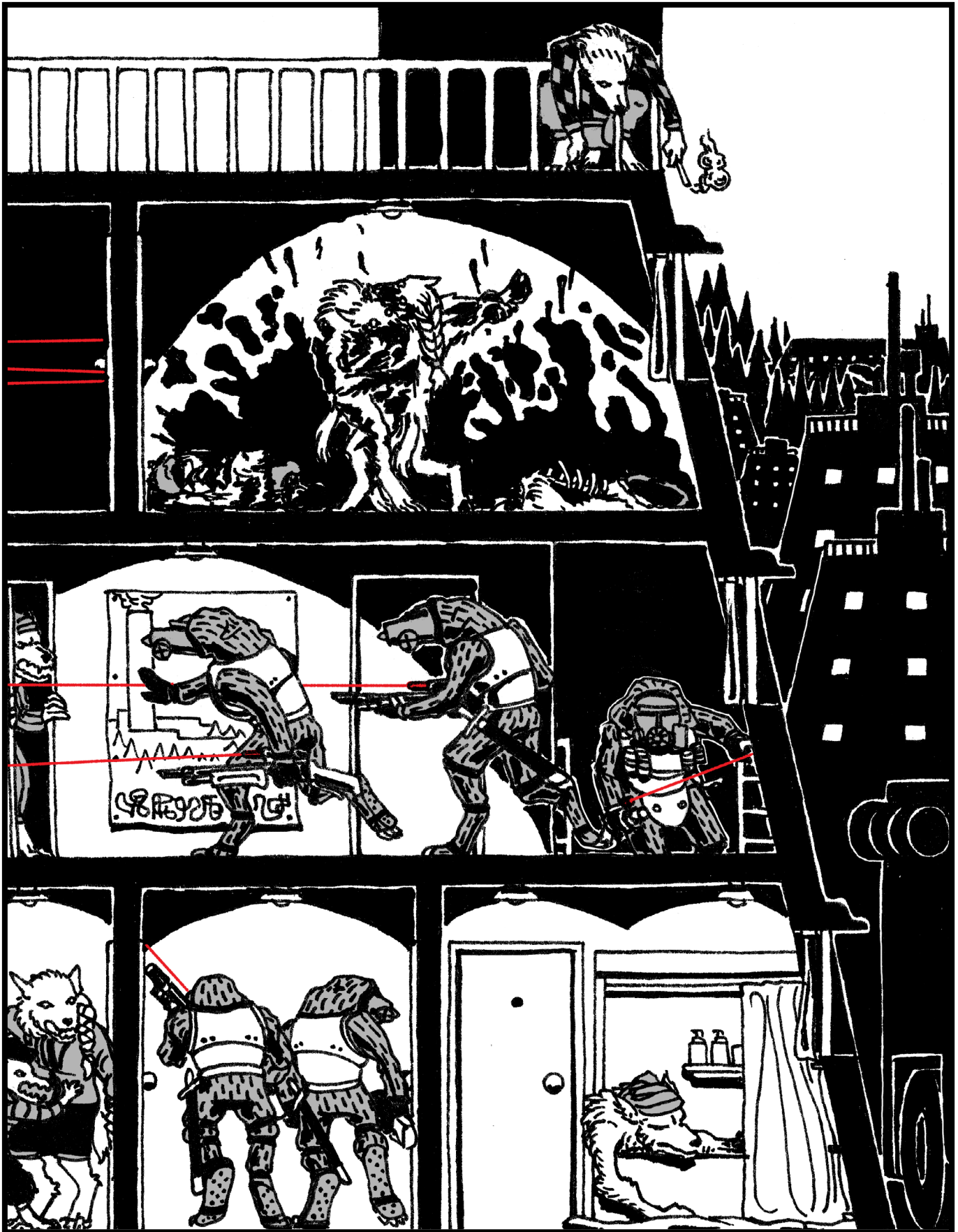

CHAPTER 4 VEHICLES & TOWED GUNS

Though the A.E.F. has been whipped into a state of basic mechanization—sporting a minimum acceptable quantity of trucks, tanks, and specialist vehicles—it cannot hope to trade armored blows with its Federal opposition for long. Without the industrial muscle to produce vast flotillas of tanks, they must carefully shepherd what they have. In fact, most A.E.F. tanks were originally produced (even if only partially) on a Federal assembly line.

Some lupar heavy metal is better than the rest. Their towed and mounted artillery are of heavier weight than Federal equivalents, putting their gunners' brute strength to use hauling high-caliber shells instead of swinging machetes. Dangerous as open ground is to them, lupar infantry can count on their artillery to have their back.

LOGISTICS

CdS-F1 "KENNEL" - IMPROVISED GUN TRUCK 10 pts / 4-2

PERSONNEL CARRIERS

VBD-U "DENMOTHER" - UNIVERSAL CARRIER 5 pts / 4-3

VBD-1 "TANNER" - ARMORED PERSONNEL CARRIER 10 pts / 4-4

VBD-2 "RAWHIDE" - INFANTRY FIGHTING VEHICLE 20 pts / 4-5

VBD-3 "MOTTE" - ARMORED PERSONNEL CARRIER 20 pts / 4-6

ARMOR

CHAR 30 "VELDJEN" - MEDIUM TANK 20 pts / 4-7

CHAR 38 "BORVO" - MAIN BATTLE TANK 40 pts / 4-8

FIRE SUPPORT

DAG-8 "BLOSSOM" - TOWED ANTI-TANK GUN 15 pts / 4-10

VBD-1B "TANNER-R" - RECOILLESS RIFLE CARRIER 15 pts / 4-11

CdS-F3 "FORESTER" - ANTI-AIR GUN TRUCK 15 pts / 4-13

CdA-25 "SAUCER" - TANK DESTROYER 20 pts / 4-15

DAG-16 "CHERRY" - TOWED HOWITZER 25 pts / 4-16

VBD SPECIAL "LUGUS" - RECOILLESS RIFLE CARRIER 25 pts / 4-18

CdA-36 "BROOMCLOUD" - SELF-PROPELLED ANTI-AIR GUN 25 pts / 4-19

CdS-F2 "AURORA" - ROCKET TRUCK 30 pts / 4-20

SPECIAL

VdIM-K "KARVE" - SPEEDBOAT 10 pts / 4-21

CdS-F1 "KENNEL"

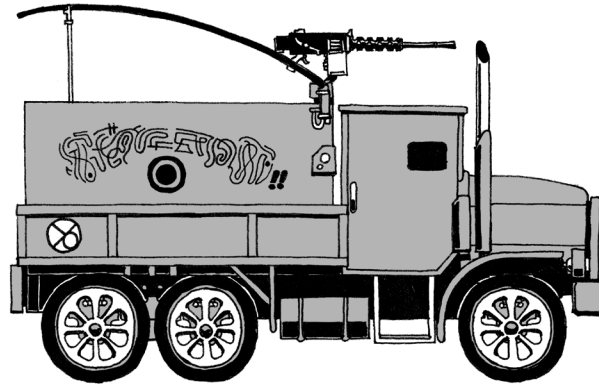

TYPE: LOGISTICS TRUCK

REMARKS

Hybrid logistics truck and convoy security vehicle. Ubiquitous in A.E.F. service. Armed with the standard MtL. 19 heavy machine gun in .50 (12.7mm) caliber. Lightly up-armored across the bed and cab with simple steel plating; resistant to rifle fire but not true anti-tank weapons.

Capable of both transporting troops and cargo while offering a modicum of protection and firepower—the minimum acceptable standard for convoy transport through the hazardous inroads of the Ebon Forest.

Goes under no official A.E.F. designation; "Kennel" is a Federal appellation owing to their frequently overloaded state. This name is considered insulting by their crews.

FEDERAL STATES-ARMY - DREKFORT M.D.C.

CdS-F1 "KENNEL" - 10 pts

IMPROVISED GUN TRUCK

Vec (W), H2, S16", M8", Q2, T2/2/1
PC (2, Rear), Resupply (6), Tow (3)

MtL. 19 .50 HMG

All, R20", A4+/6+, S2/3, D2, Turret

FEDERAL STATES-ARMY - DREKFORT M.D.C.

I have seen countless obliterated Kennels. There is a resilient myth among the dogs that death in an ammunition cookoff is instantaneous.

I can almost hear them:

"I smell them, Rhodri. I hear the beat of the guns. Quickly, let me see them! Quickly, through the mud!"

- Johannes Veeneman, F.S-A. General Staff

VBD-U “DENMOTHER”

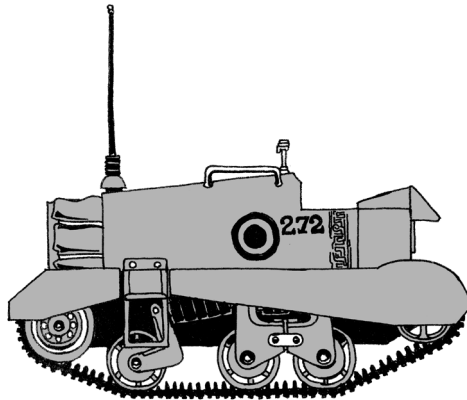

VBD-U “DENMOTHER” - 5 pts
UNIVERSAL CARRIER

Vec, H1, S16”, M8”, Q2, T3/2/1+
PC (1, Any)

This unit uses a 40x40mm base. Cannot have embarked units and desants at the same time. Embarked units can fire any one non-Melee weapon as if it were a Small Arm and are identified with the vehicle. Units embarked may spot and be spotted by Sense.

Lenus Automatic .45, driver’s issue
All, R2”, A4+/4+, S1+/1+, D1,
Small Arm

An engine without a roof. Where there is gasoline and tool kits there are Denmothers. We do not have the blue soldiers’ mighty warhorses. But a donkey will do.

- Conchar Goronwy, Chasseur, 96e Infanterie

Lenus Automatic Pistol, .45 Long.

Somehow, someway, still standard issue. It’s got to be a pride thing. The Lenus was the first automatic pistol the A.E.F. ever adopted, and one of the first all-dogface designs. I mean, just look at the thing; it’s all kinds of fucked up.

The best way I can describe it is as a sort of tiny naval rifle—the battleship kind—complete with a little screw breech. It’s singularly unpleasant to fire. Similar caliber to ours, but a lot more powder. Also, the whole damned thing jumps backwards at you when you pull the “trigger” (a big lever).

You oughta try it sometime. It’s fun.

- Rayleigh Irving, Federal Intelligence

TYPE: UNIVERSAL CARRIER

REMARKS

Diminutive, long-served ultralight personnel carrier. Too small to carry a squad. Retrofitted with universal, mechanically stabilized mounting points for heavy weapons.

FEDERAL STATES-ARMY - DREKFORT M.D.C.

VBD-1 "TANNER"

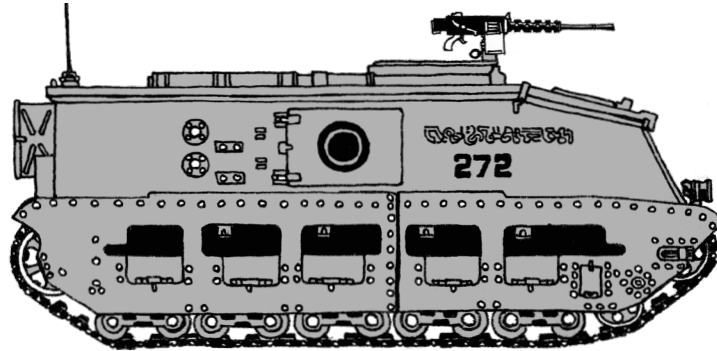

TYPE: ARMORED PERSONNEL CARRIER

REMARKS

The standard APC of the A.E.F.'s sparse mechanized forces. Itself a functional, if somewhat barebones, personnel carrier. Armed and armored for self-defense rather than carrying the fight to the enemy; its job is to safely deliver its troops and then withdraw.

The sole armament is a .50 caliber (12.7mm) heavy machine gun, pintle mounted on the commander's hatch. While frontline modifications often include a gun shield, it is not a factory-issue item.

Displays amphibious capabilities, using a water-jet system copied from the Federal Type 60 APC (see **FM 100-1-8X**).

FEDERAL STATES-ARMY - DREKFORT M.D.C.

VBD-1 "TANNER" - 10 pts

ARMORED PERSONNEL CARRIER

Vec, H2, S32", M8", Q2, T4/4/3
Amphibious, NBC, PC (3, Rear)

Mtl. 19 .50 HMG

All, R20", A4+/6+, S2/3, D2, Turret

FEDERAL STATES-ARMY - DREKFORT M.D.C.

The seats remove your hair when you stand. They are preferable to the long march and the shell splinters.

The ramp is hydraulic. When that is broken, the hand crank saves lives. A Tanner does not burn quickly.

- Conchar Goronwy, Chasseur, 96e Infanterie

VBD-2 "RAWHIDE"

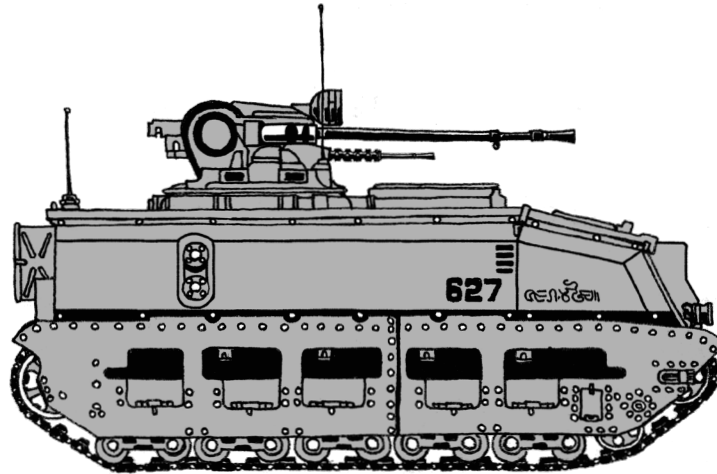

TYPE: INFANTRY FIGHTING VEHICLE

REMARKS

Modification of the VBD-1 APC into an infantry fighting vehicle. Apart from a light up-armor, the Rawhide boasts a radar-based active protection system for increasing survivability against infantry RPGs and recoilless rifles. The pintle heavy machine gun and commander's cupola have been removed in favor of a new turret and smoke launchers.

Mounting a 1-inch (25.4mm) autocannon and the standard .50 caliber (12.7mm) HMG, the Rawhide represents a significant firepower upgrade over the Tanner. Its troop capacity is inferior and its amphibious capacity, while ostensibly retained, is no longer practically usable considering its increased weight and higher center of gravity.

Aside from the White Gloves (who operate modified Bantams; see **FM 100-1-8X**), the VBD-2 is typically seen in the highest-quality A.E.F. formations.

FEDERAL STATES-ARMY - DREKFORT M.D.C.

VBD-2 "RAWHIDE" - 20 pts

INFANTRY FIGHTING VEHICLE

Vec, H2, S32", M8", Q2, T5/5/4
Active Protection (1), NBC, PC (2, Rear)

Mtl. 19 .50 HMG

All, R20", A4+/5+, S2/3, D2, Turret

APX-30 1-inch Autocannon

All, R32", A4+/5+, S4/6, D2,
 Ammo 4, No CC (Inf.), Turret

Mle. 254 2.3-inch Smoke Launchers

Gnd, R0", A++/+++, D1, Ammo 1,
Light Indirect (0), No CC, Smoke (2")

FEDERAL STATES-ARMY - DREKFORT M.D.C.

The dogfaces aren't terrible engineers; they just don't have a lot to work with. That beautiful turret's mated to the only light hull they've got in any quantity.

- Rayleigh Irving, Federal Intelligence

VBD-3 "MOTTE"

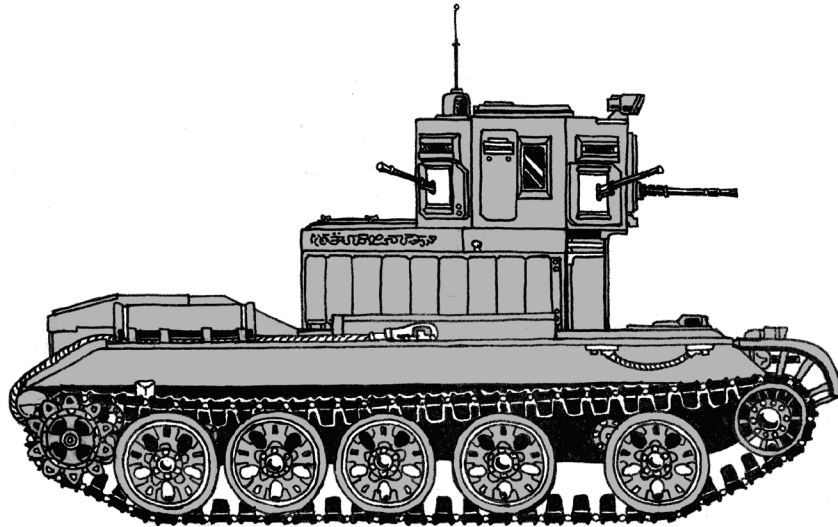

TYPE: ARMORED PERSONNEL CARRIER

REMARKS

A unique product of extensive battlefield salvage and severe industrial bottlenecks in the Ebon Forest. The Motte is little more than a refurbished, up-armored Razorback hull (often retrieved from wholly burnt-out tanks) mated to an indigenously manufactured "tower" sporting several machine guns of varying caliber.

Tank-tough, but with relatively poor troop carriage. Designed for heavy convoy security as a rolling fortress of sorts. Often deployed to the front as an assault vehicle capable of withstanding anti-tank weapons.

Because of its resilience and all-around antipersonnel firepower, it is well-suited to urban combat. Internal Security maintains and operates the majority of Mottes in the Ebon Forest's inventory.

FEDERAL STATES-ARMY - DREKFORT M.D.C.

VBD-3 "MOTTE" - 20 pts

ARMORED PERSONNEL CARRIER

Vec, H2, S32", M8", Q3, T16/10/6

NBC, PC (2, Rear, Front)

Mle. 38C .30 MG, swivels

All, R12", A4+/5+, S1/1+, D2, Turret

Mtl. 19 .50 HMG

All, R20", A4+/5+, S2/3, D2,
Multi-Gun

Mle. 254 2.3-inch Smoke Launchers

Gnd, R0", A++/+++, D1, Ammo 1,
Light Indirect (0), No CC, Smoke (2")

FEDERAL STATES-ARMY - DREKFORT M.D.C.

Wreathed in smoke and festooned in bone. A siege tower for the modern palisade. The hull has tasted fire before.

- Conchar Goronwy, Chasseur, 96e Infanterie

CHAR 30 "VELDJEN"

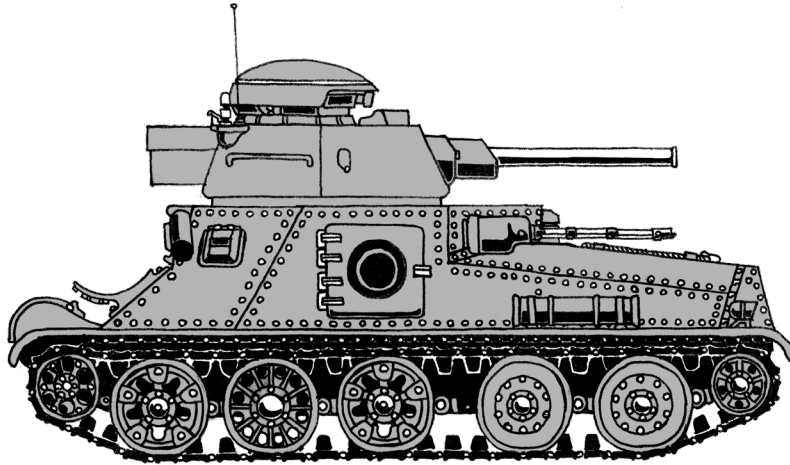

TYPE: MEDIUM TANK

REMARKS

Staple second-line tank of the Army of the Ebon Forest. Acquired variously from indigenous manufacture, decades-old captures, and foreign materiel aid programs. Relative to the modernized Veldjens in Federal service (see **FM 100-1-8X**) the gun is inferior, but great pains have been taken to upgrade its armor and powerplant to a more modern standard.

Due to its high mechanical reliability and relatively low weight, the Veldjen is well liked by lupar tankers. It is capable of enduring both the local terrain and their poor supply of replacement parts. The hatches are overly small by lupar standards and the armor's protection is inadequate compared to a true main battle tank, but the Veldjen remains ubiquitous nonetheless.

Almost all Veldjens in luparic service are equipped with a sponson flamethrower.

FEDERAL STATES-ARMY - DREKFORT M.D.C.

CHAR 30 "VELDJEN" - 20 pts

MEDIUM TANK

Vec, H2, S32", M8", Q2, T10/6/5
NBC

Mle. 38C .30 MG

All, R12", A4+/6+, S1/1+, D2, *Turret*

SA19 3-inch Gun

R32", A4+/6+, D1, Ammo 6,
No CC (Inf.), Slow Round, Turret

→ 3-inch APHE

Vec, S8/12

→ 3-inch HE-Frag

Inf/Vec, S3/3, *Ignore Cover (1)*

LF4 Sponson Flamethrower

Inf/Vec, R8", A3+/3+, S1+/1+, D3,
Ammo 3, *Ignore Cover (2),*
Multi-Gun, Rear Attack

FEDERAL STATES-ARMY - DREKFORT M.D.C.

CHAR 38 "BORVO"

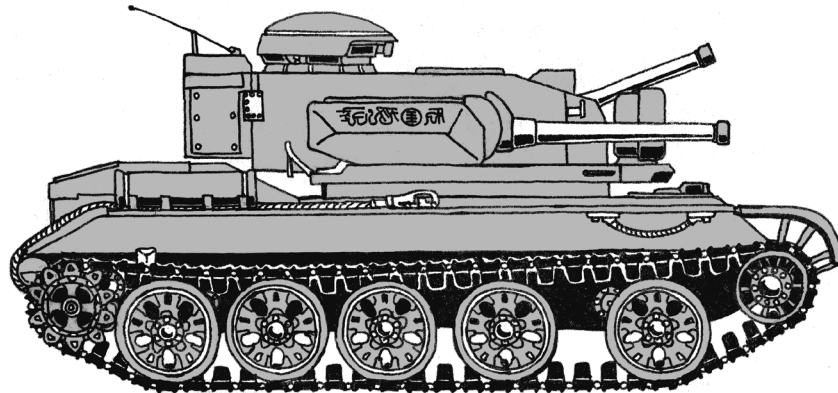

TYPE: MAIN BATTLE TANK

REMARKS

A unique product of extensive battlefield salvage and severe industrial bottlenecks in the Ebon Forest. The Borvo is little more than a refurbished Razorback hull (often retrieved from burnt-out tanks) and an indigenously manufactured turret sporting twin 3-inch (76mm) auto-loading guns.

While the armor-piercing performance of the main guns is low relative to larger-bore competitors, the Borvo's rate of fire and generous ammunition supply makes it excellent at supporting infantry attacks and destroying enemy light armor.

Fire control is augmented by a bulky radar gunsight, comparable in performance to Federal thermal optics packages.

FEDERAL STATES-ARMY - DREKFORT M.D.C.

We are lucky this beast inspires no jealousy.

- Johannes Veeneman, F.S-A. General Staff

CHAR 38 "BORVO" - 40 pts

MAIN BATTLE TANK

Vec, H2, S32", M8", Q2, T14/10/6

NBC

Mle. 38C .30 MG

All, R12", A4+/5+, S1/1+, D2,
Thermal Sights, Turret

SA19B 3-inch Dual Guns

A3+/4+, Ammo 6, *Barrage (2),
Thermal Sights, Tracking Anti-Air,
Turret*

→ **3-inch APHE**

Vec, R40", S8/12, D1, *No CC (Inf.),
Slow Round*

→ **3-inch HEAT**

Inf/Vec, R40", S9/1+, D1,
*No CC (Inf.), Shaped Charge,
Slow Round*

→ **3-inch Canister**

All, R20", S1/1+, D3,
Defensive CC (Inf.)

Mle. 254 2.3-inch Smoke Launchers

Gnd, R0", A++/+++, D1, Ammo 1,
*Light Indirect (0), No CC, Smoke (2"),
Turret*

FEDERAL STATES-ARMY - DREKFORT M.D.C.

SUPPLEMENTAL FILES

THE FEDERAL thinks of the tank when he thinks of war. He sees a great mass of steel with grinding treads and a glowering gun-stare. When he is hidden under his cupola he may as well not exist. The big-gun exchanges are made between tanks and not men. It is a war of steel and not flesh.

We do not think this way. Our old stories are of war at the grapple. We are stirred by the sword and the pistol and teeth. Even now our machetes are put to practical work. In the compounds we are trained to use them well. Not for useless ceremony but for the campaign: how to whack to clear brush and how to split bone. Yet it is plain to see it is not enough.

I pity the men in the tanks. They understand they are wanted only by necessity. They are the runts who can fit without effort in the encaging steel. They are the ones whose right eyes are stamped with the disks of the gunner's sight—whose bumps and burns are patterned—who reek of oil and propellant. It has settled into their shaven pelts and skin so finely that it will never come out. They are components of their machine and it sets them apart.

No right-thinking man would mistreat them for this. It is unspoken knowledge that they are the ones who are burnt when they do not escape, who fight plenty with poverty. When their tanks roll on parade the learned observer sees the decades encrusting them beneath the fresh paint and jubilant banners.

- Conchar Goronwy, Chasseur, 96e Division d'Infanterie

LIGHT TANK, "SOMFR"

SOMFR's gone bust, now. The time when the Regency Council gave the wink-and-nod to the myriad secret societies in its armed forces has passed—the current man in the high collar is awfully afraid of that sort of thing (with good reason). The best engineers are in the various State Bureaus now, living the good life under armed guard. Not like the old days, when every dog of stature had some second job under his rose cap.

Well, while they didn't last, their efforts did, in a way. The *SOMFR* (the real design designation is lost to history; it and its designers are one and the same) was an old light tank, a contemporary to the *Veldjen*. A little big-tracked, with this sort of moorhen-chick look, but lots of engine power where it was needed. It pioneered the prone driver position that they've made dogma now to the point of hacking it into their *Razorback* rebuilds. They were proud of the *SOMFR*, like any other modern technology that they can build by themselves. "We can make tanks, too!"

It's no longer in use anywhere, at least by the Regency's armed forces. There's only so far you can take a little turret ring like that. But the drivetrain and lower hull have enjoyed a working retirement. Look at almost any *lupe* APC or light track: you'll see those little shielded wheels somewhere.

- Rayleigh Irving, Federal Intelligence

DAG-8 "BLOSSOM"

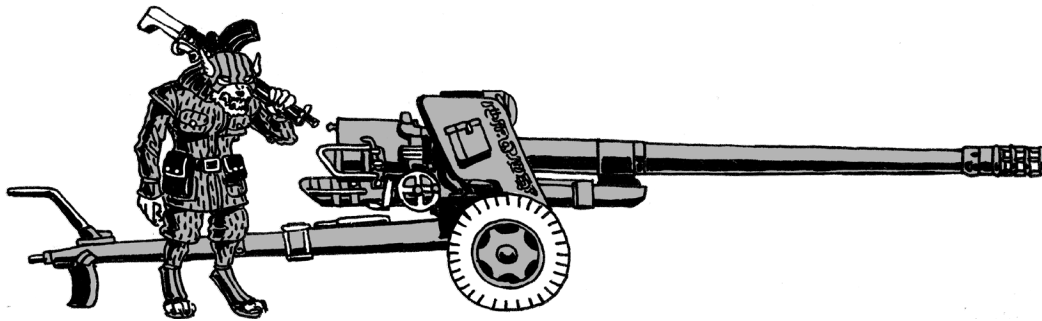

TYPE: TOWED ANTI-TANK GUN

REMARKS

Towed 3.3-inch (85mm) antitank gun. Low profile, sturdy, and light enough to be manhandled more easily than most towed guns. Ubiquitous in second-line A.E.F. formations that lack access to modern anti-tank weapons in significant quantities.

Primary ammunition loads include sabot and high explosive rounds. As 85mm sabot has difficulty defeating modern tanks at range, A.E.F. doctrine specifies that anti-tank guns be placed in flanking positions or fired from ambush at short range.

Most Blossoms are retrofitted with a basic radar gunsight and fire director similar to that of the Borvo main battle tank. This system's capabilities are overall comparable to Federal thermal optics packages.

FEDERAL STATES-ARMY - DREKFORT M.D.C.

DAG-8 "BLOSSOM" - 15 pts

TOWED ANTI-TANK GUN

Vec (C), H1, S32", M3", Q2, T2/1/1

Mle. 38 .30 LMG

All, R10", A4+/5+, S1/1+, D2,
Small Arm

DAG-8 3.3-inch Gun

R40", A3+/xx, D1, Ammo 4,
No CC, Thermal Sights

→ 3.3-inch Sabot

Vec, S12/18

→ 3.3-inch HE-Frag

Inf/Vec, S3/3, Ignore Cover (1),
Slow Round

FEDERAL STATES-ARMY - DREKFORT M.D.C.

We dig the gun in carefully. The long barrel lays flat like a fallen tree and we cover it with fresh foliage. We wet the ground so that the muzzle blast will not kick up dust. We test the fire control radar again and again. When the blue tanks come we will have to hold our fire until they are right on top of us.

- Conchar Goronwy, Chasseur, 96e Infanterie

VBD-1B "TANNER-R"

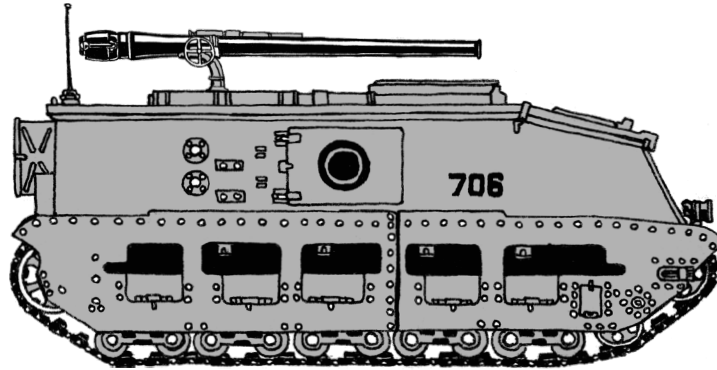

TYPE: RECOILLESS RIFLE CARRIER

REMARKS

Modification of the VBD-1 APC into a fire support vehicle, armed with the heavy TAP 30 recoilless rifle on a roof mount. Although it is as poorly-armored as the Tanner, the Tanner-R remains a significant threat owing to its firepower and range of ammunition types.

Standard ammunition issue includes HEAT (for anti-tank/anti-materiel) and canister (anti-personnel) loads, as well as smoke shells to prepare engagements.

Though most of the troop compartment has been repurposed as an ammunition locker, enough space remains for a very basic troop carriage capacity. The original amphibious water-jet system is also still functional.

FEDERAL STATES-ARMY - DREKFORT M.D.C.

VBD-1B "TANNER-R" - 15 pts

RECOILLESS RIFLE CARRIER

Vec, H2, S32", M8", Q2, T4/4/3
Amphibious, NBC, PC (1, Rear)

Mle. 32 .30 Self-loading Rifle

All, R8", A4+/4+, S1/1+, D1,
Small Arm

TAP 30 4.2-inch Recoilless Rifle

Ammo 4

→ **4.2-inch HEAT**

Inf/Vec, R28", A4+/6+, S12/2, D1,
*No CC (Inf.), Shaped Charge,
Slow Round*

→ **4.2-inch Canister**

Inf/Vec, R14", A4+/6+, S1/1+, D4,
Defensive CC (Inf.)

→ **4.2-inch White Phosphorus**

Gnd, R28", A4+/6+, S1+/1+, D1,
*Ignore Cover (2), No CC, Rear Attack,
Smoke (3")*

FEDERAL STATES-ARMY - DREKFORT M.D.C.

The TAP 30 is the only rifle too big for them to carry. They hate when you say that.

- Johannes Veeneman, F.S.A. General Staff

SUPPLEMENTAL FILES

I HAD NOT SEEN sixteen winters when I was sent to the rigs. The trains had come for that moon's take and I had been caught scrawling the old signs on the side of the abattoir cars, the signs our fathers' fathers taught us then. I do not remember what my aim had been, nor what they told my family of my punishment.

I remember the first time I saw the salt water and I remember the crossing, bodies packed onto the open deck of the barge. Grey sky, grey water, grey trunks of concrete and canopies of latticed steel, each rig standing apart like waystones marking the old paths along the waves. The acrid scent that had hung after the trains when they left and the scent of iron and of blood. It began to rain, thin drops that sliced at me through my pelt. I flattened my ears and shivered. I did not realise then the luxury it would become.

The work stains us with filth, grease and oil. It sets into your pelt and never comes out, rots the fur and blisters the skin at the eyes and nose and lips. They tell us the shifts are 16 hours, but there is no timepiece to keep us, no sun to see by on the drill floor. Only the quotas and the shift bell and the toil. Sometimes men are too slow, and the heavy iron tongs take fingers and swinging metal crushes bone. Sometimes the men with the clean pelts in the control box drill too fast and pipe bursts and mud and steel saw flesh and cave skulls, and the men with the clean pelts shake their heads and the bodies are carted away. Some men cannot take it, and they gnaw on their fingers and snap at the rest of us when we come too close. For them the Regent's men watch us through their heavy masks with only clawed hammers in tight clenched hands, they cannot risk a spark.

We sleep two decks up in darkness, nose to tail. When the bell calls us to our next shift I pray to my father's fathers that another will fail to rise and I will be chosen to carry the body to be cast over the side. There I can see the grey sky and the grey water and the waystones stretched out across the horizons. The flat-faced men watch us from further out at sea, sometimes they bring their cigar shaped boats in close enough you can catch the scent of their tobacco on the wind before slipping back beneath the waves. Sometimes another rig will catch alight and burn for shifts upon shifts and they tell us it is the flat-faced men's doing, and the quotas rise. I do not believe them. They cannot risk a spark.

- Llewellyn Chaucier, Rig No. 89

A DOG which has been beaten to make him useful is more dangerous than one beaten for pleasure, for that time which the dog has been given to live is time to be beaten. He is anxious, and yearns to be saved, yet also to bite: idleness vexes more than labor, for if free he has none to bite but his savior.

When the Regent sank our merchants in the Sea of Lights, Admiral Hargew proposed thunder runs on rigs in Olariuma as an escalation strategy. The resulting memorandum said, "we will not stoop to their level in politics by threatening countervalue as a form of leverage." But that is not what I meant. I meant that I do not want to feel responsible for the Regent's slaves, one way or another.

- Johannes Veeneman, F.S-A. General Staff

CdS-F3 "FORESTER"

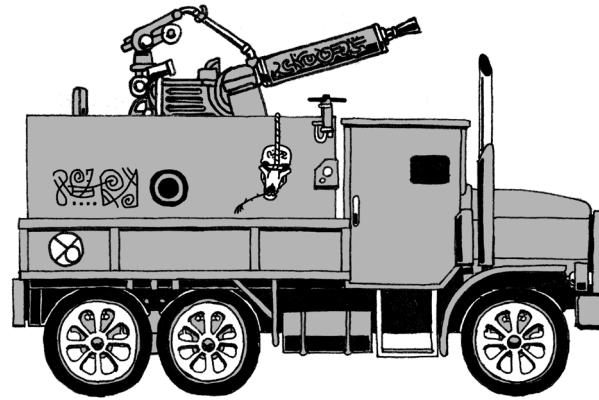

TYPE: ANTI-AIR GUN TRUCK

REMARKS

Modification of the Kennel logistics and convoy security truck featuring an improved heavy machine gun armament at the cost of storage space. Originally produced by A.E.F. field workshops, it has been widely copied by rural clan armorers and various other anti-state forces.

Primary armament is the AMA-2 anti-aircraft complex, consisting of twin .60 (15.2mm) heavy machine guns sharing a flat water jacket. While now deficient in its original anti-aircraft role, it is still effective against helicopters, and excellent against infantry and light vehicles.

The AMA-2 is mounted high enough to clear the Forester's rifle-resistant armor and can fire forwards over the cab. Roll-overs are easy in the hands of inexperienced drivers.

FEDERAL STATES-ARMY - DREKFORT M.D.C.

CdS-F3 "FORESTER" - 15 pts

ANTI-AIR GUN TRUCK

Vec (W), H2, S16", M8", Q2, T2/2/1
Tow (2)

AMA-2 .60 Dual HMGs

All, R24", A4+/6+, S3/4, D3,
Turret, Tracking Anti-Air

FEDERAL STATES-ARMY - DREKFORT M.D.C.

The truck drivers are not so perfect a salve against ambushes as they claim. Even old trees are no defense against thumb-wide bullets with explosive cores. But the enemy still tries.

When the hewing tracers stopped I went forward. I came across the body of a Creag clansman in his mail-skin. Of his braids I could not say. His head and upper torso had been carried off. I tasted his brave heart.

- Conchar Goronwy, Chasseur, 96e Infanterie

SUPPLEMENTAL FILES

WHAT'S A LUPAR?

Ask a professor at the Royal Institute and he'll tell you that he's a human being, just like you. Ask a mountain man from Cydoland and he'll tell you that his dog beat him over the fence. Ask a waykeeper and he'll say he's a cursed man. His flesh is like yours, but twisted. Not a wolf, but an imitation of one. Look at the shape of the skull, the lay of the jaw. He might be on to something.

The curse, the curse, the curse. They'll never get over it. How could they when it's staring back at them in every mirror? Everything is wrong. You see it in their eyes when they talk to you. A human face looks more familiar to them than one of their own.

It used to be that they were bent around working it off. Finding a way for their children to have flat faces, bare skin, to not get twitchy around their siblings' throats when unsupervised. Since the rise of the Regency it's changed somewhat. Now the party line is that they're the best of both worlds. Man and beast in a superior whole. It's just a question of addressing some thousand-year teething problems. One coping mechanism for another, I guess.

The research programs cast a pretty wide net, as far as we know. Spiritual and scientific work alike. They want to control the curse, re-twist their own flesh as they see fit. Make a better man: stronger, faster, smarter, more self-controlled. The vast majority of their results are living mistakes, disposed of as pack mules and berserkers. Some aren't. They can never figure out what went right.

- Rayleigh Irving, Federal Intelligence

I GREW UP *on the old estate of my family; they were wealthy enough to hold on to it. My childhood was happy. I had open land to run free in, and I was alone or among kin as I saw fit. More than once I came home with an injury and a grin on my face. We avoided the cities and the polyclinic. I was told their walls, though clean, still stank with the smell of once-opened bellies. To attend to our family we instead retained a flat-faced doctor from the lowlands of Rygos.*

Everything fascinates a young boy, but little could equal seeing the doctor. This was a man, too! No flesh-curse hung around his neck like a torc. My tutor in the woods had said and sung much about this. Here was the real thing. The doctor's skin was bare. His hair sat massed atop his head and it looked no different in summer or winter. I was not allowed to nip him in play. Although my family could trust him, and paid him well, an armed guard always shadowed him.

Later I grew jealous of the doctor. I came to realize that the way he walked, spoke, and drank from a necked bottle were more familiar in my bones than my own habits. They were the little motions common to all men. I had been warped. It enraged me. I wondered at times if I could find something like him under my skin. Unlike some, I never dug.

- Roul Lydon, Lieutenant, Escadron de Chasse 1/1

CdA-25 "SAUCER"

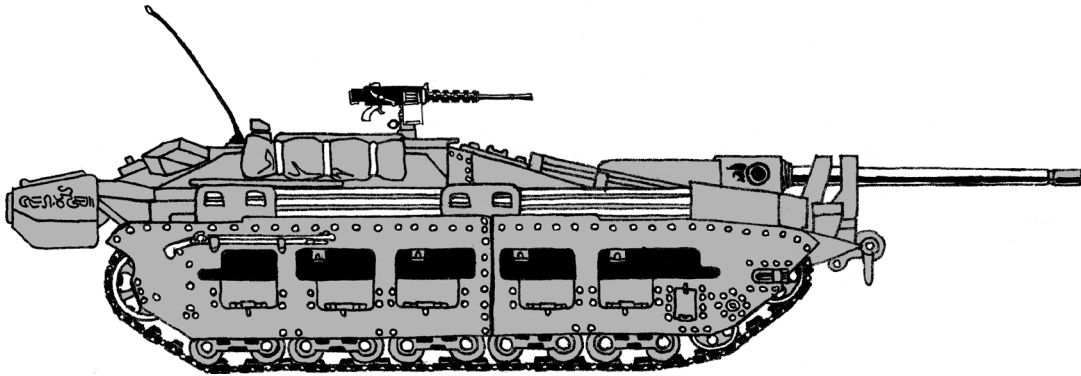

TYPE: TANK DESTROYER

REMARKS

Low-profile, thin-skinned tank destroyer. Relatively fast for its weight class. Armed with a 2.5-inch (63.5mm) high-velocity gun. No explosive shell is provided, but a standard .50 (12.7mm) heavy machine gun on a ring mount provides well-rounded general capability.

As a turretless, low-profile vehicle, the Saucer is best suited to ambush roles—capable of concealing itself even in brush, fields, or other low occluding terrain. It is not very survivable in gunnery duels with tanks.

A.E.F. tactical manuals dictate that Saucers should disengage after firing a few rounds from each prepared position, but poor crew training and general bloodthirstiness often conflicts with this.

FEDERAL STATES-ARMY - DREKFORT M.D.C.

CdA-25 "SAUCER" - 20 pts

TANK DESTROYER

Vec, H1, S32", M10", Q2, T6/3/2

NBC

Mtl. 19 .50 HMG

All, R20", A4+/6+, S2/3, D2,
Turret

SA25 2.5-inch High Velocity Gun

Vec, R40", A4+/5+, S12/18, D1,
Ammo 6

FEDERAL STATES-ARMY - DREKFORT M.D.C.

An unexpected rival to the Veldjen-M. The lupes devised an elegant gun, but didn't put it in a turret, thus inciting a lot of suicidal theatrics from Saucer drivers in the name of the hunt. Remember: wolves don't look away from their prey. If a lupe can't turn his head, he won't run circles. He'll run forward.

- Johannes Veeneman, F.S-A. General Staff

DAG-16 "CHERRY"

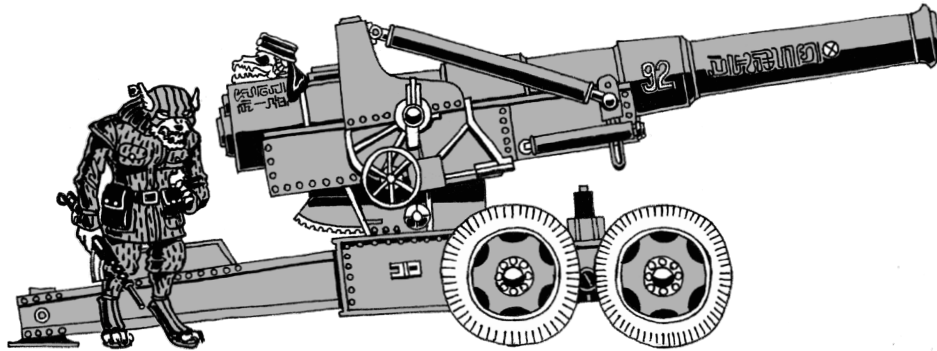

TYPE: TOWED HOWITZER

REMARKS

Heavy, large-bore towed artillery forming the backbone of the A.E.F.'s dismounted "leg" formations. Even on the modern battlefield, crowded with heavy metal, big guns are king: invaluable both in supporting assaults or stiffening defenses with heavy fire support.

Luparic artillerymen leverage their race's high strength to handle 7.8-inch (200mm) shells in similar fashion to the F.S-A.'s own 152mm equivalents. Consequently, guns of this caliber are issued as standard support weapons rather than being relegated to special heavy batteries.

Despite its age, the DAG-16 complex is notoriously efficient in counter-battery fire and anti-tank roles from concealed ambush positions.

FEDERAL STATES-ARMY - DREKFORT M.D.C.

DAG-16 "CHERRY" - 25 pts

TOWED HOWITZER

Vec (C), H1, S24", M2", Q2, T1/1-/1-

Mle. 32 .30 Self-loading Rifle

All, R8", A4+/4+, S1/1+, D1,
Small Arm

DAG-16 7.8-inch Howitzer

Ammo 3, No CC

→ 7.8-inch HEAT

Inf/Vec, R40", A3+/xx, S16/3, D1,
Shaped Charge, Slow Round

→ 7.8-inch Frag

Gnd, R∞", A4+/xx, S[D6], D3,
*Air-Filling, Heavy Indirect (3),
Radius (3")*

→ 7.8-inch Canister

All, R20", A4+/xx, S1/1+, D6,
Radius (2")

→ 7.8-inch Smoke

Gnd, R∞, A++/xx, D4,
Heavy Indirect (3), Smoke (5")

FEDERAL STATES-ARMY - DREKFORT M.D.C.

SUPPLEMENTAL FILES

WE'D BEEN GETTING HELL on Shave Ridge (thus earning it its namesake; before us it was just Feature 5) for two weeks when, without further warning, the hail of heavy shells lifted like the end of a tropical torrent, and we were able to peek out of our fighting positions.

Nothing but the misty wall of pines and torn rock faced us. Not a lupar to be seen. They gave us that hill. Command said it was a "poison pill", some bighair stuff I don't guess about. Sent the 78th in to scout what the Lupes were up to.

Well, we get no resistance going into the treeline; very uncharacteristic of the foe. Walk all the way up to their concealed firing positions—way behind a hill, no direct line of sight or anything. Way further back than we'd thought the whole time, based on what we knew of their pieces. How they had been shaving that ridge of trees and men from such a distance with such accuracy was a mystery to us.

Then I tripped over a wire hidden in the loam. We followed it a klick, and it ended in a crude wooden post. We found a clawtappy, a thing like a finger telegraph, in a tree with a big glass "ear" hanging on a strap. Someone else found similar going the other direction, up another tree. Dead lupe hanging on that one, his ear still connected by a latex tube to the glass bowl.

We figured it out eventually. Those dogs had never really wanted Shave Ridge anyway. The 52nd was just target practice for this system they were cooking up. A sort of crude audial targeting computer, I guess. We've had more of this since. Explains why we keep finding finer and finer threads on their old guns, too.

Y'know how good they are at hearing our patrols creep up on 'em. No sense in that, whether in the dark of night or the din of battle. Well, they put that to use with the big guns. HQ reckons they could pick out the sound of our counterbattery fire. Maybe even hear our gun crews swearing. That's why we changed the doctrine. No counterfire when Lupe 200s are known to be on the line, now!

- Junior Sgt. Piet Asterman, 2-78 Cavalry Scouts

IN OLDEN TIMES our dead were boiled to clean them of their meat. Today I trade Eoghan for a bottle of herb spirits. The top of his mouth was pierced by a needle from the hairless men's cannons and he says the brew tastes vile now.

There is a picture of a dead man on the bottle. A skeleton. He smiles because he has no lips with which to frown. We were picked to fire the rockets because we can read better than most. I read on the bottle that it was brewed in a vessel for cleaning the dead.

I put a measure in the pan and drink it. My heart makes a sound like someone has caught it in their fist, then released it. The cleaners knew their trade.

-Laval, Grande Batterie No. 37

VBD SPECIAL "LUGUS"

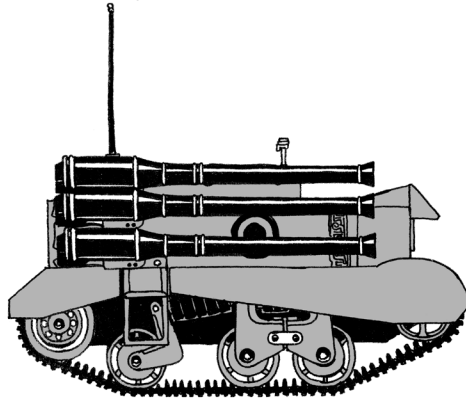

TYPE: RECOILLESS RIFLE CARRIER

REMARKS

Field modification of the VBD-U light carrier into a light fire support/tank destroyer complex. Nothing more than a set of six TAP 25 recoilless rifles (a competing design bureau's entry against the ubiquitous TAP 30) bolted to the frame.

While as vulnerable to fire as its parent hull, the Lugus is capable of unleashing grossly disproportionate firepower for its weight class. Not many ground targets remain mission-capable after a volley of six 4.2-inch (106mm) rounds. Various examples have been recovered with canister and smoke rounds preloaded into some of their recoilless rifles.

A modern optics package has been installed in the gunner's station to enable accurate spotting at its effective range.

FEDERAL STATES-ARMY - DREKFORT M.D.C.

VBD SPECIAL "LUGUS" - 25 pts

RECOILLESS RIFLE CARRIER

Vec, H1, S32", M8", Q3, T3/2/1+

This unit uses a 40x40mm base.

Lenus Automatic .45, driver's issue

All, R2", A4+/4+, S1+/1+, D1,
Small Arm

TAP 25 4.2-inch Recoilless Rifle Battery

Ammo 6, *Barrage (6, Point)*

→ **4.2-inch HEAT**

Inf/Vec, R28", A4+/6+, S12/2, D1,
*No CC (Inf.), Shaped Charge,
Slow Round*

→ **4.2-inch Canister**

Inf/Vec, R14", A4+/6+, S1/1+, D4,
Defensive CC (Inf.)

→ **4.2-inch White Phosphorus**

Gnd, R28", A4+/6+, S1+/1+, D1,
*Ignore Cover (2), No CC, Rear Attack,
Smoke (3")*

*A six-barreled surprise with tiny dimensions.
The joke goes both ways once it's empty.*

- Rayleigh Irving, Federal Intelligence

CdA-36 "BROOMCLOUD"

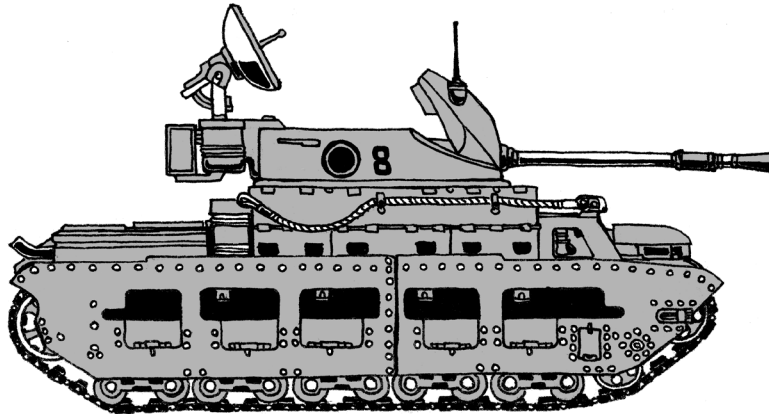
**TYPE: SELF-PROPELLED ANTI-AIR GUN****REMARKS**

Short-range A.E.F. air defense complex. Centered around a single-barreled APX-40 autocannon firing proximity-fused 1.5-inch (38mm) shells. Basic target acquisition and tracking is offered by a last-generation fire control radar.

As an open-topped vehicle, the Broomcloud is generally unsuited to combat areas heavily saturated with artillery fire or NBC threats. Its low weight, however, endears it to A.E.F. commanders operating in the difficult terrain typical to their homeland.

A large stock of ammunition permits both extended firing and an additional anti-infantry fire support duty.

FEDERAL STATES-ARMY - DREKFORT M.D.C.

CdA-36 "BROOMCLOUD" - 25 pts
 SELF-PROPELLED ANTI-AIR GUN

Vec, H2, S32", M10", Q3, T5/3/1+

Mle. 32 .30 Self-loading Rifle

All, R8", A4+/4+, S1/1+, D1,
Small Arm

APX-40 1.5-inch Autocannon

All, R36", A4+/4+, S5/7, D2,
 Ammo 6, No CC (Inf.),
Radar Anti-Air, Turret

FEDERAL STATES-ARMY - DREKFORT M.D.C.

The Broomcloud has a kind of picture-book quality to it. It is nostalgic, that is to say. It returns you to a time before the Federals had answered the air defense question, when radar was something you found inside a big silver dish. It has every hallmark of that bygone era, from the gunner's open canopy to the spindly saucer quivering over his shoulder.

Frankly, I think it's cute.

- Johannes Veeneman, F.S-A. General Staff

CdS-F2 "AURORA"

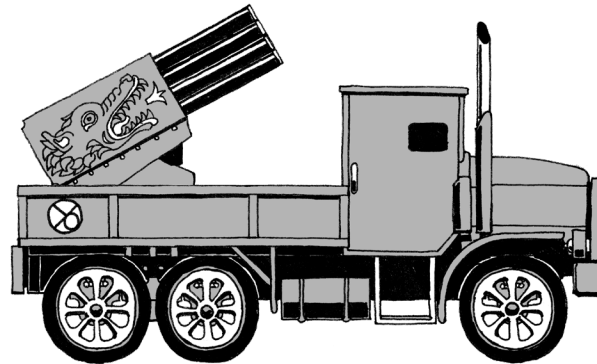

CdS-F2 "AURORA" - 30 pts

ROCKET TRUCK

Vec (W), H2, S16", M8", Q2, T2/2/1

Mle. 32 .30 Self-loading Rifle

All, R8", A4+/4+, S1/1+, D1,
Small Arm

Mle. 13 5.2-inch Rocket Rack

Gnd, R12-∞", A4+/5+, S6/6, D2,
Ammo 6, Air-Filling,
Ignore Cover (1), Heavy Indirect (2),
No CC, Saturating (6)

FEDERAL STATES-ARMY - DREKFORT M.D.C.

The rockets are a test of patience. We endure hardship for the promise of reward. We lift the bombs and force them into the tubes. The smell of the fuel makes us all drool. Laboriously we plug the wires. We pack the rest into the bed. When we fire we will drive away quickly, before the flying men reply with a storm of their own.

The first rocket fires, followed by the others in sequence so fast they make one sound. I hold my mouth open to protect my ears. My lips peel back, my tongue lolls. I am on my mother's farm again and I am running. In this dream I am faster than my littermates. I will be the first this time.

We drive away. Exhaust from the rockets has scorched the flowers.

-Laval, Artilleur, Grande Batterie No. 37

TYPE: ROCKET TRUCK

REMARKS

Modification of the CdS-F1 gun truck into a mobile rocket artillery system (retaining the up-armored cab). 5.2-inch (132mm) rocket barrages are not exceptionally accurate, but capable of saturating a wide area with a rapid volley, after which the Aurora can quickly reposition and reload.

VdIM-K "KARVE"

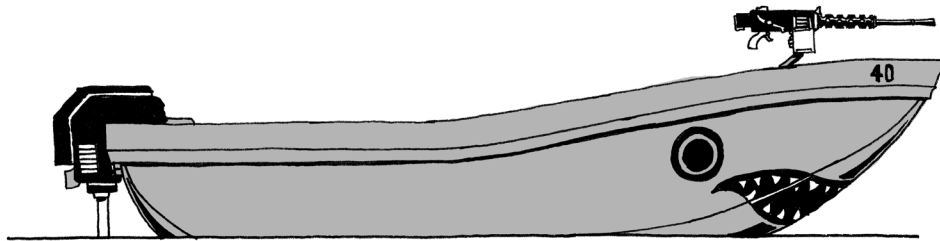

TYPE: SPEEDBOAT

REMARKS

Lightweight military motorboat developed for covert insertions along the Ebon River's Federal-side banks. It has since been adopted for general assault and transport service. Fast, spacious enough for a couple squads, and armed with a single heavy machine gun to suppress enemies on the approaching riverbank.

FEDERAL STATES-ARMY - DREKFORT M.D.C.

An ancestor of mine, Teru Goronwy, was a retainer of Clan Roskonala. His lot was the river. He made many voyages to the other clans and the lands of the flat-faced men. He spilled blood on seawatered decks. His vessel was the karve.

It was wood and not aluminum. Where now squats the outboard motor there was an oar to steer with. The clan's heraldry flew on the great square sail. It was a ship of commerce as well as war. Most of Teru's voyages were peaceful.

There are still traders on the Ebon River. They brave it although it has been heavily torpedoed. Sometimes the enemy falls on them while they cross his country. It is an occupation that permits no silver hairs. But the bounties are worth it.

- Conchar Goronwy, Chasseur, 96e Infanterie

VdIM-K "KARVE" - 10 pts
SPEEDBOAT

Vec, H1, S32", M12", Q2, T2/2/1
PC (4, Any), Watercraft

Mtl. 19 .50 HMG
All, R20", A4+/4+, S2/3, D2, Turret

FEDERAL STATES-ARMY - DREKFORT M.D.C.



CHAPTER 5 AIRCRAFT

If A.E.F. ground vehicles are lackluster, the same cannot be said for its rotorcraft. The Regency Council preferentially funds its best formations with modern equipment as can be acquired. Unlike their Federal opponents, they place great stock in the helicopter as a future combat platform. Helicopters are able to both rapidly transport men and materiel, and apply great pressure with their high mobility and powerful armaments. Accordingly, the Ebon Forest's aircraft industry receives better funding and more attention than its automotive equivalents.

Unlike Federal combat aircraft, designed for ground support and long-duration combat patrols under turboprop propulsion, the fixed-wing craft of the Air Army of the Ebon Forest (A.A.E.F.) are made for short and dangerous missions. They field a variety of jet interceptors and attack aircraft, built in limited numbers to a high manufacturing standard.

HELICOPTERS

VZ61 "CHARIOTS" - DUCTED FAN PLATFORMS	15 pts / 5-2
AES514 "BACKBONE" - HEAVY LIFT HELICOPTER.....	20 pts / 5-3
AES805 "TORNADO" - ATTACK HELICOPTER.....	30 pts / 5-4

PLANES

R-2 "CHIEN DE CHASSE" - RECONNAISSANCE AIRCRAFT	10 pts / 5-5
AD-48 "FALCONET" - LIGHT ATTACK AIRCRAFT	20 pts / 5-6
AD-IV "GROGNARD" - FIGHTER-BOMBER	35 pts / 5-7
MD-II "MIST" - AIR SUPERIORITY FIGHTER	40 pts / 5-8

VZ61 "CHARIOTS"

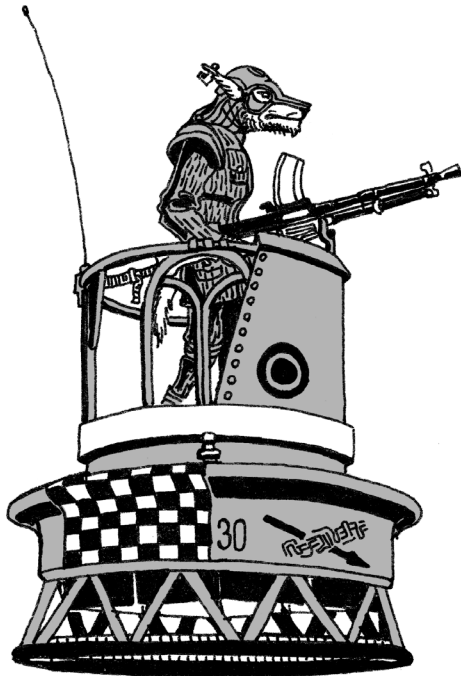

VZ61 "CHARIOTS" - 15 pts
 DUCTED FAN PLATFORMS

Air, H1, S24", M18", Q2, T1+/1/1

This unit uses a 40x40mm base and can be depleted as if it were an infantry squad. When landed, unit class counts as Inf (S); it may fire all weapons and enter close combat as if it were infantry. May land in forests and inside of buildings as a squad-sized garrison.

Mle. 38 .30 LMG

All, R10", A4+/5+, S1/1+, D2, Turret

Mle. 44 3.5-inch RPG

All, R8", A4+/6+, S9/1+, D1,
 Ammo 4, Shaped Charge,
 Slow Round, Turret

FEDERAL STATES-ARMY - DREKFORT M.D.C.

TYPE: DUCTED FAN PLATFORMS

REMARKS

One of several experimental State Aircraft Bureau projects fast-tracked to production against recent Federal territorial gains. Little more than a small engine and ducted fan surmounted by a chariot-esque platform (hence its users' appellation for the vehicle). Steering is via leaning; mounting points are provided for the typical chasseur-issue small arms.

Chariots permit rapid airmobile infantry deployment at the cost of certain inherent downsides; the inability to operate inside personnel carriers and greater difficulty obtaining effective cover, among others.

FEDERAL STATES-ARMY - DREKFORT M.D.C.

You'd never believe it if you didn't see it.

Many of my fellow analysts (I don't want to call them buddies) have this weird impression that the Ebon Forest is a bunch of growling primitives clutching stamped-steel rifles. Well, they are, but my coworkers seem to think that's all they can do. They'll point to Veldjens and Cherries and what-have-you and conclude that we're comfortably ahead.

The truth is that the dogfaces have to pick and choose what they really pour money into. For the Regent, that choice wasn't ground vehicles. I guess he felt like he wasn't gonna beat us at our own game. In any case, they can build enough of them to give us a real headache, and, somehow, they've got the spare avgas too.

I'm more worried about the latter, really.

- Rayleigh Irving, Federal Intelligence

AES514 "BACKBONE"

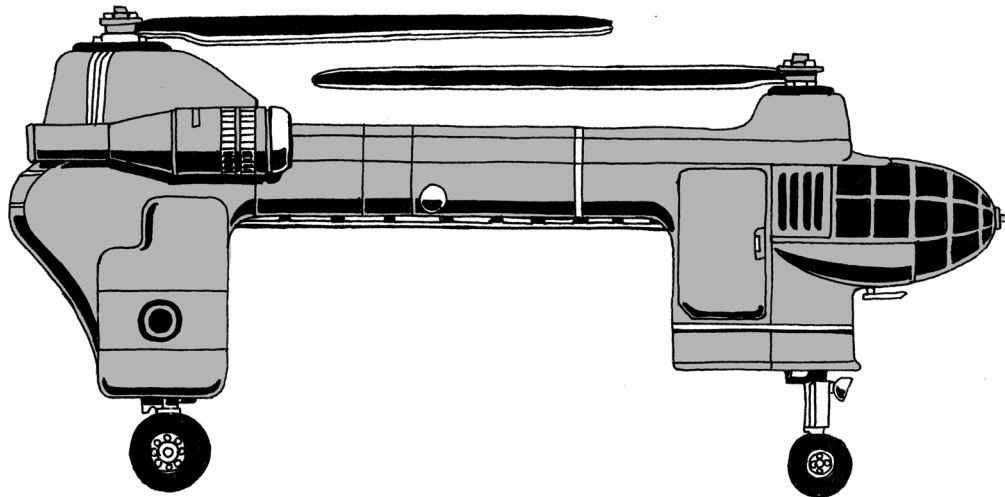

TYPE: HEAVY LIFT HELICOPTER

REMARKS

Heavy transport helicopter arranged in a "skycrane" layout. Necessary systems are concentrated in fore and aft sections, with a reinforced "spine" equipped with airtowing gear. Capable of lifting most vehicles—a flying prime mover.

A deployable "bridge" provides a stable foothold for infantry underneath the spine. Thick gantry shields offer these troops superior protection while permitting them to employ any of their carried weapons.

The pilot, as in most State Aircraft Bureau designs, lies prone in a "glass teardrop" canopy. Limited space for an upright flight engineer-radioman exists in a cabin behind him. The twin counter-rotating propeller shafts are capable of partially retracting for storage in low subterranean hangars.

FEDERAL STATES-ARMY - DREKFORT M.D.C.

AES514 "BACKBONE" - 20 pts

HEAVY LIFT HELICOPTER

Air, H2, S32", M24", Q2, T3/2/3

Decoy Protection (2), PC (2, Sides), Tow (10)

Embarked units can fire any one non-Melee weapon as if it were a Small Arm and are identified with the vehicle. Units embarked may spot and be spotted by Sense.

FEDERAL STATES-ARMY - DREKFORT M.D.C.

Waste not, want not. The A.E.F. hates to leave even a burnt hulk unclaimed, let alone a perfectly good tank or howitzer. Give them a few minutes to hold the perimeter and one of these ugly beasts will be along to pick up the loot, leaving with guards clinging to its rigging.

- Rayleigh Irving, Federal Intelligence

AES805 "TORNADO"

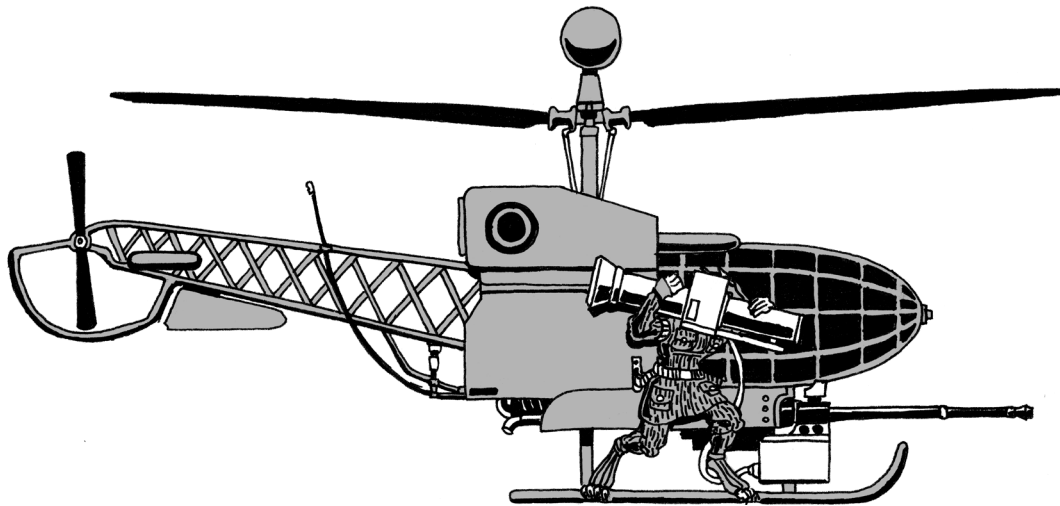

TYPE: ATTACK HELICOPTER

REMARKS

Light attack helicopter produced by the State Aircraft Bureau. A highly skeletal design with most of its armor being bulletproof glass and applique sheets over an exposed engine. Very fast and agile. Notoriously effective, despite its ad-hoc origins, in "pop-up" ambushes from behind cover.

Primary armament is the APX-30 1-inch (25.4mm) autocannon for attacking ground targets or slow-flying aircraft. Infantry retention straps are provided along the hull; those examples lacking a mounted SD84 ATGM complex instead sport an anti-tank gunner clinging to the skids.

As with the Backbone, Tornado pilots fly prone, occupying a bulletproofed "glass teardrop" cockpit. The Tornado's light frame and low profile make it easier to conceal when landed than most attack helicopters.

FEDERAL STATES-ARMY - DREKFORT M.D.C.

AES805 "TORNADO" - 30 pts

ATTACK HELICOPTER

Air, H1, S32", M32", Q3, T2/2/2

Decoy Protection (2)

APX-30 1-inch Autocannon

All, R32", A4+/5+, S4/6, D2,
Ammo 4

SD84 4.7-inch Missile Launcher

S15/2, D1, Ammo 2,
*Door Gun (Front, Sides),
Guided Missile (2), No CC,
Shaped Charge*

→ **ATGM Guidance Mode**

Vec, R6-60", A3+/4+

→ **MANPADS Guidance Mode**

Air, R60", A4+/4+

FEDERAL STATES-ARMY - DREKFORT M.D.C.

"Aim and wink at the moons."

- *Luparic idiom*

R-2 "CHIEN DE CHASSE"

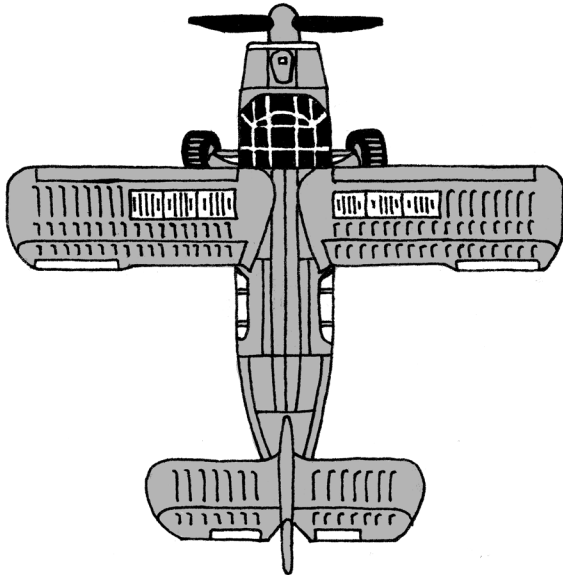

R-2 "CHIEN DE CHASSE" - 10 pts
OBSERVATION AIRCRAFT

Air (CAS), M10", Q2, T2, E0
Loiter

*Does not break designation when it moves.
Designation is broken when the target leaves
frontal arc. Counts as E3 in dogfights.*

Mtl. 19 .50 HMGs, dual

All, R4", A6+, S2, D2

Mle. 7 Laser Designator

All, R40", A++, D1, Designator

FEDERAL STATES-ARMY - DREKFORT M.D.C.

TYPE: RECONNAISSANCE AIRCRAFT

REMARKS

Common, ubiquitous trainer, reconnaissance and fire direction aircraft. Originally devised as a crop-duster and forestry aircraft for use in the rural Ebon Forest. Designed to operate on dirt runways and on packed snow, with no supporting infrastructure. Its mechanical simplicity, highly forgiving handling, and practically nonexistent stall speed endear it to trainee A.A.E.F. pilots.

In combat service, the Chien de Chasse is typically employed as a forward controller for artillery batteries, painting targets for Cherries with a laser designator and adjusting their fire by radio.

FEDERAL STATES-ARMY - DREKFORT M.D.C.

Leave the concrete jungles, avoid the rail lines carving through the trees, and by and large the Ebon Forest looks the same as it was when men first laid eyes on it. It's easy to forget what century you're in, and the locals will be all too willing to help with that. But not for long. Sooner or later, you'll hear the sound of a sewing machine passing overhead.

It's not just faster, but safer, to commute between woodland villages by air. Load her up with caged poultry and eggs, smoked meat and tubers. Take the straight road, far over the stormy black sea of treetops beneath you. Land into a headwind and set her down gently, on the big truck-like tires: a good pilot won't break a single egg.

Even while the runway thralls are unloading, the pilot in his braids and torc is poring over the popping engine. Doesn't matter if he can hardly tell you who taxes him, or why the blue airplanes shot his brother out of the sky. He'll disassemble that engine with his eyes closed.

- Rayleigh Irving, Federal Intelligence

AD-48 "FALCONET"

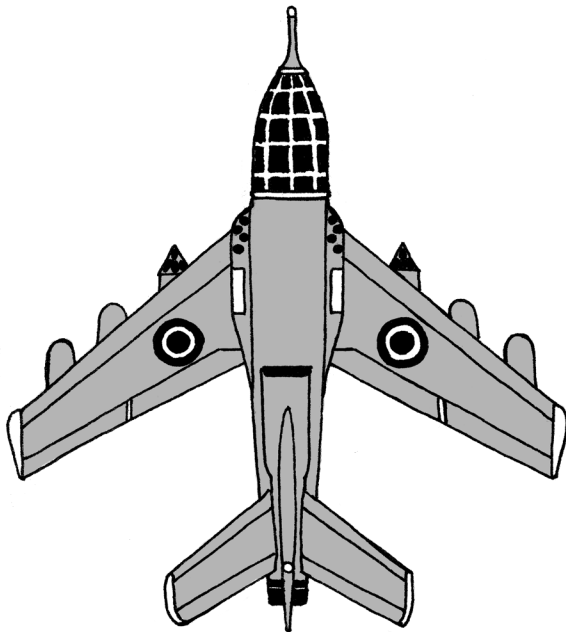

AD-48 "FALCONET" - 20 pts

LIGHT ATTACK AIRCRAFT

Air (CAS), M14", Q3, T2, E1

Decoy Protection (2)

Mtl. 19 .50 HMGs, octet

All, R4", A4+, S2, D3, Radar Anti-Air

LR-49 2.7-inch HEAT Rocket Pod

Inf/Vec, R6", A4+, S7/1+, D4,

Ammo 2, Barrage (2), Shaped Charge, Slow Round

BLG-64 500-lb. HE Cluster Bomb

Gnd, R0", A2+, S4, D2, Ammo 4,

Air-Filling, Rear Attack, Saturating (4)

TYPE: LIGHT ATTACK AIRCRAFT

REMARKS

A subsonic single-engine light jet aircraft common in the A.A.E.F.'s reserve squadrons. As a now-aging design, its primary role has shifted from air superiority to ground attack and training roles. Primary armaments include pod-mounted 2.7-inch (68.6mm) HEAT rockets and 500-lb. (227 kg) cluster bombs: a "bomb truck", dispersing explosives over a long strafing run.

The Falconet's speed and maneuverability exceed that of an Air Corps-standard turboprop fighter without the use of the latter's sprint motor. Without an autocannon its air-to-air capabilities are limited.

FEDERAL STATES-ARMY - DREKFORT M.D.C.

The Falconet's long in the tooth, although (by necessity) it's not deployed as suicidally as we do our aircraft. It's not a lot to look at, nor is it very fast, but it's still a prestige design: the first of theirs that's all home-made, all Ebon Forest design and manufacturing. It meant—and means—a lot to them; like the railways and the state theaters. Proof that they're a real country, that their culture and works aren't just what they've stolen from us.

Naturally, it's a propaganda darling; every snot-nosed pup in state school has scrawled one of these flying pipes in his notebook at least once. Rumor even has it that the current Regent cut his teeth flying one, as a young junior officer. Nobody can ever seem to pin down which unit he served with, though. I doubt he'd want the glory himself.

- Rayleigh Irving, Federal Intelligence

"Flatface, shoot me in the cockpit. Not out here, like a dog!"

- Torg Malvigny, Lieutenant, Escadron 2/12, upon capture

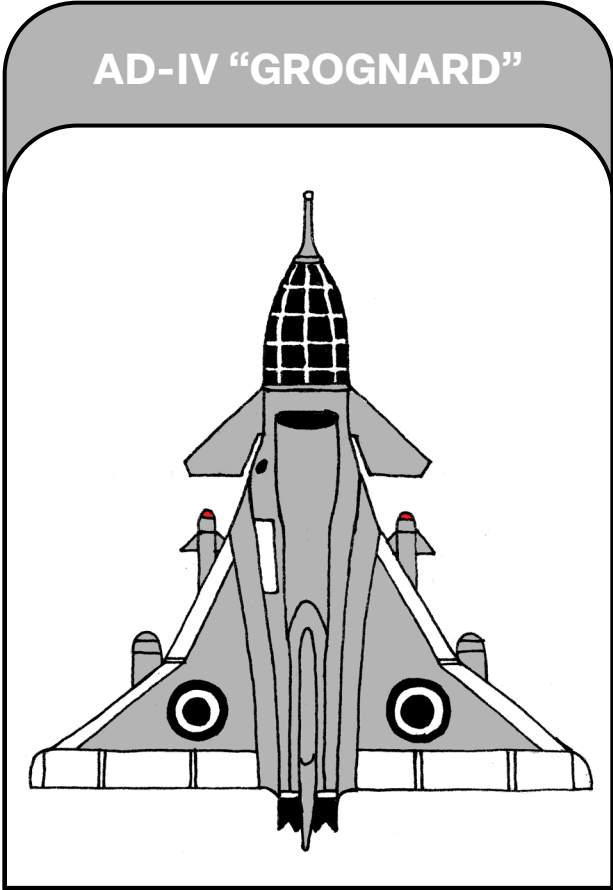

TYPE: TACTICAL BOMBER

REMARKS

Versatile fighter-bomber, standard in higher-grade A.A.E.F. squadrons. In keeping with typical luparic fighter doctrine, its pilot flies prone on an ejection sled, with visibility offered in every direction but rearwards. This full usage of the nose imposes a size limit on the aircraft's radar, rendering it reliant on ground control for interception and guidance.

Equipped for television-guided bombing and decisive interception with infrared homing missiles; its pilots instead favor dogfighting with its 1.4-inch (35.5mm) revolver cannon.

FEDERAL STATES-ARMY - DREKFORT M.D.C.

AD-IV "GROGNARD" - 35 pts
FIGHTER-BOMBER

Air (CAP), M16", Q3, T3, E2
Afterburner, Decoy Protection (2)

APX-50 1.4-inch Revolver Cannon
 All, R8", A4+, S5, D3, Ammo 3,
Radar Anti-Air

MA-67 4.7-inch Infrared AAM
 Air, R30", A3+, S6, D1, Ammo 2,
*Air-Filling, Guided Missile (1),
 Homing*

SD68 8-inch TV-Guided Bomb
 Gnd, R40", A3+, S8, D1, Ammo 2,
*Air-Filling, Guided Missile (2),
 Radius (3"), Rear Attack*

The Regent isn't stupid, but that doesn't mean his paranoia hasn't gotten the better of him before. Take the Grognard's design team. They were the best for the job, but they were also old money: former secret society members, amateur philosophers and painters, that sort of thing. Dogs that didn't like being shut up in an isolated cage, no matter how gilded. They drank absinthe, and talked, and figured the Regency wouldn't touch them.

Even with the project bosses scrambling to put together a new design team from nothing, the Grognard was too far along to cancel. I think the old dog regretted giving the orders. See, Grognard pilots tend to have seedy records—not enough to disappear, but enough to nail them to their rung of the ladder. They act out. They paint their craft like a flying circus troupe; they break ranks to intercept our fighter wings all on their own. They get away with all of it.

I guess it's too hard to kill people like you.

- Rayleigh Irving, Federal Intelligence

MD-II "MIST"

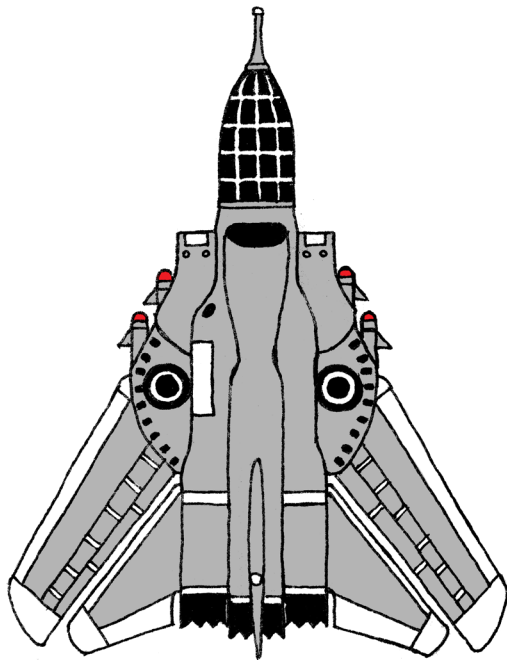

TYPE: AIR SUPERIORITY FIGHTER

REMARKS

High-performance, tri-engine supersonic jet interceptor. Limited production run; deployed from nuclear-hardened subterranean aircraft shelters surrounding Carcalhight. Designed for short-run, rocket-assisted takeoffs from underground launch rails. A pure interceptor, lancing towards incoming radar tracks while under ground-based guidance.

As a rare and great investment for the Ebon Forest, the Mist is armed with the best air-to-air missiles available and superlative gunner's optics. Caution and ground anti-air support are advised when engaging.

FEDERAL STATES-ARMY - DREKFORT M.D.C.

MD-II "MIST" - 40 pts
AIR SUPERIORITY FIGHTER

Air (CAP), M20", Q4, T3, E3
Afterburner, Decoy Protection (2)

APX-50 1.4-inch Revolver Cannon
 All, R8", A3+, S5, D3, Ammo 3,
Radar Anti-Air

MA-67B 4.7-inch Infrared AAM
 Air, R36", A3+, S6, D1, Ammo 2,
*Air-Filling, Guided Missile (1),
 Homing*

MA-62 7.9-inch Semi-Active AAM
 Air, R60", A4+, S8, D1, Ammo 4,
*Barrage (2, Point),
 Guided Missile (1), No CC*

FEDERAL STATES-ARMY - DREKFORT M.D.C.

I lay in the cockpit. As if stalking prey in the bush, I'm flattened to the ejection sled. I'm glad that my tail is docked and my mane shaved; both now demand to stand on end. Blood thumps behind my eyes although I'm elevated at the angle of the launch rail. There are still a few pills in my flight suit. By now my pupils are like little pins. I feel as if trapped and repress the urge to cry out.

Somewhere outside Carcalhight, there is a deep pit in the earth. In it there is a vast computer. With nerves of wire that run through the roots it listens to a chorus of radar arrays across the land. From them it whispers into my aircraft's ears: a vector. A hostile radar track.

Ignition. I'm forgotten beneath the noise and force. The first seven seconds of flight are automatic. In the fourth second I regain consciousness and seize the yoke. My missiles are my teeth; my growl is lost in the roar of the jets.

- Roul Lydon, Lieutenant, Escadron 1/1

CHAPTER 6
EMPLACEMENTS

To further offset its disadvantages in ground warfare against more mobile and heavily-armed foes, the A.E.F. deploys a variety of expedient area denial systems and traps against both personnel and vehicles. All ground troops are trained to dig and conceal stake traps and incendiary fougasses as well as strike from concealment from foxholes; bolstered against airborne recon with eccentric, rocket-boosted bouncing mines, they are a fearsome guerilla force.

EMPLACEMENTS

STAKE PIT - ANTI-PERSONNEL TRAP	6-2
FLAME FOUGASSE - ANTI-TANK TRAP	6-2
MdRA. 2 "GRENOUILLE" - ANTI-HELICOPTER MINES	6-4
SPIDER HOLES - UNDERGROUND HIDES	6-4

STAKE PITS
ANTI-PERSONNEL TRAP

Trap

Infantry that trigger this trap gain max pin.

Stake Pit, improvised
Inf, A++, S*, D3, Radius (3"),
Undetectable
*Always rolls 6+ to kill regardless of Toughness.

FEDERAL STATES-ARMY - DREKFORT M.D.C.

TYPE: ANTI-PERSONNEL TRAP

REMARKS

Thin wooden stakes planted at the bottom of a covered ditch. Luparic claws give them a natural proficiency in digging, allowing the speedy construction of shallow stake pits by small groups, even non-engineers.

Low lethality, but a cheap and effective deterrent of infantry.

FEDERAL STATES-ARMY - DREKFORT M.D.C.

“Marck explained to me that he was not so much ‘playing dead’ as ‘being dead’. He really did feel like he was going to die, since the blood loss had rendered him dumb and drowsy. He shut up and laid still until his platoon could arrive to dig him out.

The dogs who set the trap eventually found him, but left without trying to pull him out. ‘They were saving me for later,’ he laughed.”

- Gerrit Ghent, from *And We Saw*, p. 244

FLAME FOUGASSE
ANTI-TANK TRAP

Trap

This trap may choose not to be triggered and may be manually triggered by a TACOM as a mission. The TACOM does not need LOS to trigger this trap. All units (friend and foe) inside Radius are instantly hit when this trap triggers. When detonated, the radius lingers on board for the rest of the match and cannot be cleared.

Flame Fougasse, improvised
Inf/Vec, A++, S3/3, D3, Ammo 1,
Rear Attack, Radius (3")

FEDERAL STATES-ARMY - DREKFORT M.D.C.

TYPE: ANTI-TANK TRAP

REMARKS

Incendiary anti-vehicle improvised explosive devised from a gasoline drum, bricks of plastic explosive, and a long-fused electric blasting cap.

The drum is placed toward the target with the plastic explosive at its back. The blasting cap detonates both the liquid within the drum and the explosive behind it, causing a shower of burning liquid.

FEDERAL STATES-ARMY - DREKFORT M.D.C.

Don't check the hatches. Don't get the extinguisher. If the commander says sit, you have blowout panels. Remember to fold your arms.

What? What else am I supposed to tell you?

- Johannes Veeneman, *F.S-A. General Staff*

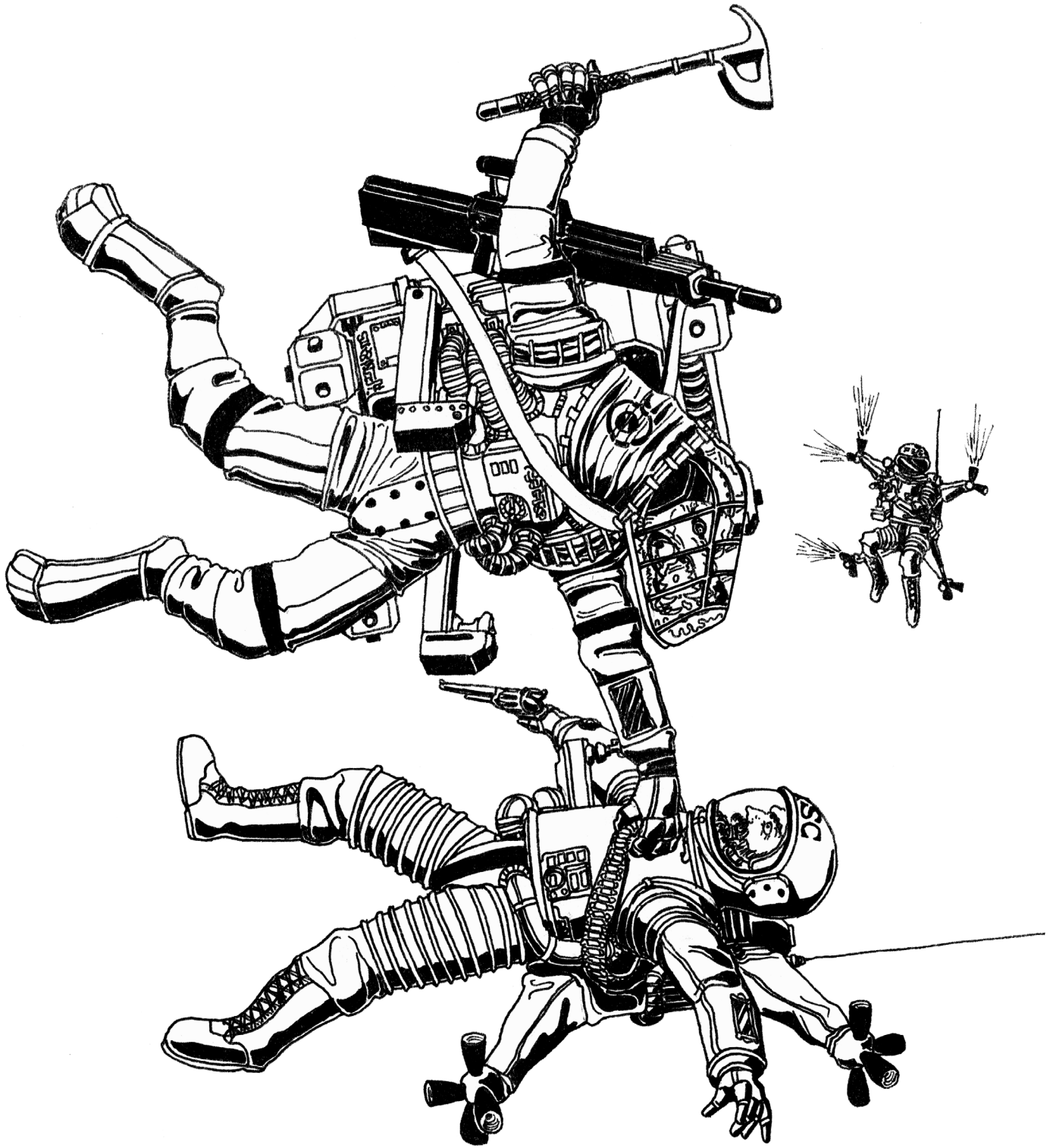

MdRA. 2 “GRENOUILLE”
ANTI-HELICOPTER MINES

Trap

Planes do not trigger this trap.

MdRA. 2 “Grenouille” Bouncing Mine
Air, A++, S1+, D3, Ammo 4,
Radius (4”), Rear Attack

FEDERAL STATES-ARMY - DREKFORT M.D.C.

SPIDER HOLES
UNDERGROUND HIDES

Fortification

Designate a 40mm x 40mm square of terrain as “spider holes”, which count as an H0 structure with a garrison capacity of 1. They do not obstruct movement, but units cannot end their movement inside of the Spider Hole without paying 1” to enter it.

Units inside may not draw LOS to those on the outside, nor vice versa. The Spider Hole may only be identified by units in basal contact. Units inside cannot be directly targeted and may only be hit by Lingering weapons during Upkeep. A unit inside a Spider Hole may spend all of its movement to move to another ungar- risoned Spider Hole within 6”, unless it must cross Void to do so.

FEDERAL STATES-ARMY - DREKFORT M.D.C.

TYPE: ANTI-HELICOPTER MINES

REMARKS

“Bouncing” fragmentary mine used for the deterrence of low-flying aircraft composed of a can-shaped warhead and a short rocket booster. Expensive by A.E.F. standards.

When the acoustic sensor detects the sound of a helicopter engine, the explosive is armed and the mine’s radar actively searches for targets directly overheard. When one is detected, the altimeter fuze is set, and the rocket launches the warhead to burst directly underneath the helicopter.

Dense area of effect, but with shrapnel too small to reliably penetrate even thin armor.

FEDERAL STATES-ARMY - DREKFORT M.D.C.

TYPE: UNDERGROUND HIDE

REMARKS

Cluster of camouflaged one-man foxholes, sometimes connected via tunnel. Soldiers within are completely concealed, and are thus unassailable, unless the spider holes are stormed or hit by infiltrating munitions such as napalm or chemical-SP (see **FM 100-1-8X**).

FEDERAL STATES-ARMY - DREKFORT M.D.C.

Look at them, you mongrels of Santagria! You shaven apes, you tin-rattlers, look!

One hundred mines, all planted by my claw! See the streaks on the bellies of your machines, hear the bellows and shrieks of your scions!

- Ulrig, Sapeur, 23e Ingénierie de Combat

And when they abandon positions, the bodies are left in what they half-knew was a grave...

- Johannes Veeneman, F.S-A. General Staff

CHAPTER 7 SCENARIO UNITS

Besides the ubiquitous clan militias, a clan chieftain or A.E.F. commander may levy a number of more exotic irregular infantry types from lesser clan households, particularly those situated in the less developed areas of the Ebon Forest.

Equipped and trained according to the ancient customs of the clans, these units combine unusual tactics with typical luparic tenacity. These relics of a former age are ill-prepared to contend with modern, mechanized armies, yet remain nonetheless daring, unpredictable, and occasionally even effective when fighting on unconventional terms. Whether they are death-seeking widows of clan warriors, airmobile clan huskarls, or big-game subsistence hunters from the deepest mists, these strange combatants can still be found collaborating with—or against—the Regency's forces.

The units below do not fall into the standard roster for this faction, but are presented for thematic scenario creation and play. Scenario units may disrupt the balance of the faction (e.g. by covering one of its major weaknesses). If you'd like to use them in a regular game, your opponent ought to agree to it.

SCENARIO UNITS

WAILING WOMEN - SUICIDE BOMBERS	5 pts / 7-2
IRONPELTS - PARATROOPER SQUAD	15 pts / 7-3
MIST STALKERS - SNIPER TEAM	15 pts / 7-4
VEHICLE CREW - LINE TEAM	0 pts / 7-5
VBD-68 "BANTAM" - INFANTRY FIGHTING VEHICLE	25 pts / 7-6

WAILING WOMEN



TYPE: SUICIDE BOMBERS

REMARKS

Suicide bombers, dressed in mourning veils and high-yield improvised explosive vests. Drawn from the widows of dead clan warriors, desiring to avenge their husbands' deaths and join them via a similarly violent death. Unarmored and otherwise unarmed, but fearless. A massed attack by wailing women punctuates the end of a clan.

Special caution is to be used when operating in proximity to luparic civilians. While the suicide vest is usually worn outside the mourning dress, elaborately hand-decorated, some suicide bombers conceal theirs.

FEDERAL STATES-ARMY - DREKFORT M.D.C.

WAILING WOMEN - 5 pts
SUICIDE BOMBERS

Inf, H1, S24", M5", Q1, T1-/1-/1-
Bloodlust, Fearless, Infiltrator, Sense (6")

Suicide Vest

All, R0", A++/++, S4/4, D2, *Melee, Radius (2")*

FEDERAL STATES-ARMY - DREKFORT M.D.C.

Petty Rygolic courtesans write hateful letters to their rivals and then poison themselves. Santagraine dames swan-dive off floating islands, trailing colorful streamers in their hands. Federal molls simply shrug and shoot themselves in the roof of the mouth.

Our women once did better. Now it is not so fashionable in the cities; but the clans remember.

- Roul Lydon, Lieutenant, Escadron 1/1

I remember the arms of my Naoghas. I met him in the raid on Cenchoras town, when we were both young. We had nothing to lose; everything to prove. Blood and sweat and torn cloth, like the young falx-bearers of old. We slept together under the stars that same night, far from the camp and the funerary pyres.

I remember the arms of my Naoghas. Frozen stiff, reaching out before him. His strong legs crushed into bonemeal by the treads of a tank. Not even he could have outran it.

I will feel his embrace again.

- Abélia Carigo

IRONPELTS



TYPE: PARATROOPER SQUAD

REMARKS

The upper crust of a clan's territorial forces (its household warriors), composed of loyal veterans with superior training to their commoner counterparts. Trained for parachute operations and reconnaissance work in dense forestry. Their name derives from their traditional war-costumes of head-to-toe chainmail, covered with patterned fabric and supplemented with concealed ballistic plates.

Their signature armament is the LfC. 46 single-shot hand flamethrower, no longer in general A.E.F. issue owing to its short range. One or a pair may be carried.

FEDERAL STATES-ARMY - DREKFORT M.D.C.

IRONPELTS - 15 pts
PARATROOPER SQUAD

Inf (S), H1, S24", M5", Q3, T1+/1/1
Bloodlust, Fearless, Paradrop, Sense (6")

Mle. 32 .30 Self-loading Rifle

All, R8", A3+/4+, S1/1+, D1,
Small Arm

LfC. 46 Hand Flamethrower

Inf/Vec, R2", A1+/1+, S1+/1+, D3,
 Ammo 2, *Ignore Cover (2),*
Rear Attack, Small Arm

OtPv. 9 30-inch Machete

Inf, R0", A1+/1+, S1/1, D2, *Melee*

FEDERAL STATES-ARMY - DREKFORT M.D.C.

The earliest lesson of substance a young boy should learn is this: never forget your humanity. You do not have paws: those are hands. You do not have fur. You have hair on your head; and, if you must refer to the stuff that clings to the rest of your accursed flesh, it is a "pelt" or your "skin", merely thrown 'round your real personage. You are no beast, but an actor playing the part. And you must be vigilant not to forget the feeling of the mask on your snout.

The chainmail skin is another mask. Let the warrior forget himself; then, what he does are not his deeds, and he may sleep lightly.

- Roul Lydon, Lieutenant, Escadron 1/1

The clans that built the Regency were wealthy. They wore plate. The clans they heeled were poor. They wore mail.

- Conchar Goronwy, Chasseur, 96e Infanterie

MIST STALKERS



TYPE: SNIPER TEAM

REMARKS

“Wild” skirmishers and huntsmen hailing from the sparsely-populated and dangerous inner woodland of the Ebon Forest. While most lupar choose to lead civilized and humanlike lives, a small number live transient and animalistic existences following large migratory prey. Effective skirmishers, but their loyalty is in material bribes and they are unlikely to stand their ground under fire.

Their traditional armament, passed down by generations and sustained through a symbiotic relationship with rural cottage gunsmiths, is a large-bore “express” rifle.

FEDERAL STATES-ARMY - DREKFORT M.D.C.

MIST STALKERS - 15 pts
SNIPER TEAM

Inf, H1, S32”, M7”, Q1, T1-/1-/1-
Amphibious, Bloodlust, Infiltrator, Sense (6”)

This unit is always considered to be in ambush when in terrain with a non-zero cover modifier. If not currently spotted, its movement and accuracy are unaffected by pin tokens.

“Express Rifle”, .50 Single-Shot
All, R20”, A2+/4+, S2/3, D1,
No CC (Inf.), Scoped, Small Arm

Teeth & Claws
Inf, R0”, A1+/1+, S1/1, D1, Melee

FEDERAL STATES-ARMY - DREKFORT M.D.C.

“Express rifle”, my ass. That’s a heavy machine gun cartridge, or at least a local reproduction. And the action itself—that trapdoor and external hammer? Ours. Somewhere they’re copying off a rifle old Willem Bluecoat left in the woods, many, many years ago.

- Rayleigh Irving, Federal Intelligence

You might mistake them for animals. Naked; wordless, except by absolute necessity; creedless, except for their instincts. No loyalty except to themselves and their immediate families. Pure and simple beasts, without our self-imposed miseries; wolves on two legs.

They grow savage, become misshapen horrors, just the same. The head can be made to forget one’s identity through deliberate effort; but the heart never forgets.

- Roul Lydon, Lieutenant, Escadron 1/1

VEHICLE CREW



VEHICLE CREW - 0 pts

LINE TEAM

Inf, H1, S24", M5", Q2, T1/1-/1-

Bloodlust, Sense (6")

This unit is placed on the board as part of the Crew Bailout optional rule.

Lenus Automatic .45 Pistol

All, R2", A4+/4+, S1+/1+, D1
Small Arm

FEDERAL STATES-ARMY - DREKFORT M.D.C.

TYPE: LINE TEAM

REMARKS

Dismounted vehicle crewmen. The A.E.F.'s mechanized forces are limited in scope by budgetary and industrial realities in the Ebon Forest. While armor is generally conservatively deployed, as a preservative measure, it is still considered preferable to lose materiel to trained manpower.

The standard armament for A.E.F. tankers, issued with frontier garrison security in mind, is the army-issue Lenus semi-automatic pistol in a necked .45 (11.43mm) caliber. While notorious for its high recoil and stopping power, any sidearm is a last resort under actual combat conditions.

FEDERAL STATES-ARMY - DREKFORT M.D.C.

*I am straining, with every last sinew,
But today is just like yesterday—
Got me cornered, body-heat in view,
And they'll joyfully chase down their prey.*

*From the high crests, come tracers streaking,
From one-fifteens lurking in the shade,
In the cold white snow our wreck is smoking,
Living targets all of us have been made!*

*The wolf-hunt has begun, it's drawing nigh
Veterans and youth—come on wolves, let's go!
Their scouts bark 'til sick; the missiles hiss on by,
Green tracers—and blood upon the snow!*

*It's as equals, our tanks and theirs begin,
Their missile-cords bind us like wire;
Gunners' hands must be firm not to miss
Setting to our fuel a raging fire!*

*A wolf always respects his tradition,
Even striplings with pelts soft as silk;
Cowardly flight is a prohibition,
Suckled in with my dear mother's milk!*

- Mathis Folcard, Cuirassier, 32e Blindée

VBD-68 "BANTAM"

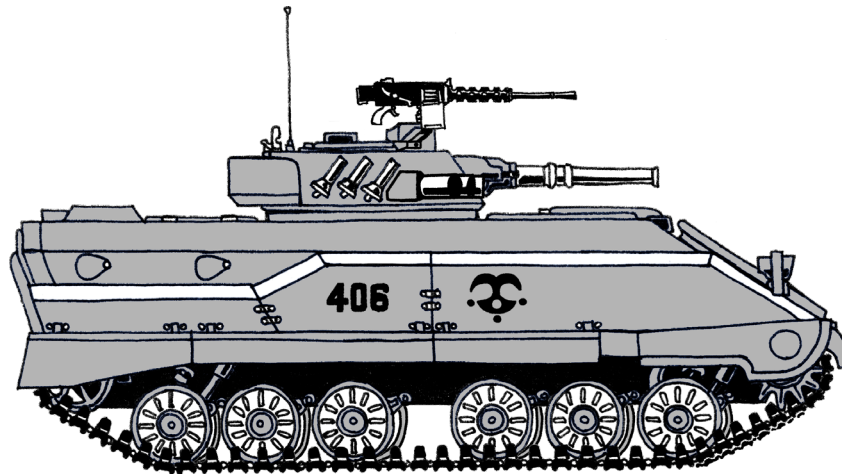

TYPE: INFANTRY FIGHTING VEHICLE

REMARKS

Export model Federal Bantam IFV (see **FM 100-1-8X**), modified specifically for the White Gloves. Sourced from a series of shell corporations at substantial expense and routed through Ezmarc. While the reason for its adoption over domestic types is unclear, it is thought that the prestige associated with Federal armor plays a part.

Primary armament is the standard 2K28 73mm low pressure gun, designated the SA-28 in luparic service. Standard HEAT and custom white phosphorus smoke rounds are typically issued.

As an export model, the VBD-68 lacks the stock Bantam's ATGM launch tubes. It has received a number of retrofits to compensate: domestic smoke grenades, a basic active protection system, and thermal sights manufactured in the Petty States (see **FM 100-3-8X**).

FEDERAL STATES-ARMY - DREKFORT M.D.C.

VBD-68 "BANTAM" - 25 pts

INFANTRY FIGHTING VEHICLE

Vec, H2, S32", M8", Q3, T6/4/4
Active Protection (1), Amphibious, NBC, PC (2, Rear)

MtL-19 .50 HMG

All, R20", A4+/6+, S2/3, D2, Turret

SA-28 3-inch Low-Pressure Gun

Inf/Vec, R22", A4+/4+, D1, Ammo 4,
No CC (Inf.), Thermal Sights, Turret

→ **3-inch HEAT**

S9/1+, *Shaped Charge, Slow Round*

→ **3-inch WP Smoke**

S1+/1+, *Ignore Cover (2),
 Rear Attack, Smoke (2")*

Mle. 254 2.3-inch Smoke Launchers

Gnd, R0", A++/+++, D1, Ammo 1,
Light Indirect (0), No CC, Smoke (2"),
 Turret

FEDERAL STATES-ARMY - DREKFORT M.D.C.

Ours is better.

- Rayleigh Irving, Federal Intelligence

APPENDIX A - ARMY SPECIAL RULES

This appendix section describes the underlined special rules of the Army of the Ebon Forest.

Bloodlust

A wolf in uniform is still a wolf. The smell of blood drives undisciplined troops into a killing frenzy.

If this infantry unit reaches six pin tokens during the Fire Phase, the unit must roll a 4+ check on a D6 to avoid going **berserk**. Place a **berserk token** on the unit if it fails.

When a unit gains a berserk token, all other Lupar infantry with the Bloodlust trait within 3" also roll to go berserk. This chain reaction will continue until all infantry succeed their checks or there are no more units with Bloodlust within range. Units do not roll to go berserk more than once per round, and they may choose to willingly go berserk.

Berserk units immediately lose *all* pin tokens and cannot gain new ones. They do not benefit from cover and must always fire at moving accuracy outside of close combat. In close combat, they fire stationary and re-roll misses. Time-to-target attacks fired by berserk units automatically miss.

During the Maneuver Phase, the owning player chooses whether each non-stationary berserk unit moves towards the nearest corpse token or the nearest enemy unit which it can possibly kill. These obligatory move actions do not cost command tokens, and occur automatically at the beginning of the phase, before normal move actions are declared by anyone.

A unit remains berserk until it is hit by a *Rally* weapon or it **sates** on a corpse token. Units with Bloodlust may choose to sate on a corpse even if not currently berserk.

Sating automatically occurs when a unit with Bloodlust ends a round in basal contact with a corpse token. In the beginning of the subsequent Support Phase, before any other actions occur, remove the corpse token. Flip the unit's berserk token to show that it is **satiated**. This unit will not roll berserk checks for the rest of the battle.

Multiple units may sate on the same corpse token if they are all in contact with it at the beginning of the Support Phase.

Bloodlust cannot trigger while within *Chemical Weapons*. Berserk units may not call or participate in brigade movement, nor can they share spotting or call missions. Embarked units do not roll to go berserk.

Special Factional Token (double-sided):

Berserk/Satiated: Blood Red/Gray

Guidance (X")

The stories and sight of the Waykeepers steel the nerves of their flock against the killing temptation.

This unit soothes friendly lupar within X inches from itself. Units which enter this radius automatically lose their berserk tokens (if berserk), and units inside of the radius cannot gain them. A unit that loses its berserk token this way does not become satiated. Units within the radius never have to roll to go berserk for any reason.

Infiltrator

Whether warden or poacher, the lupar are natural hunters—the wilder, the better.

This unit may deploy up to 16" away from your deployment edge, into occluding terrain (or terrain that puts infantry into ambush, such as dead ground or entrenchment), *before* any standard deployment by either side. It does not get a subsequent move. Multiple players with Infiltrators must alternate their deployments.

Rally (Salt)

Potent, artificial, unmistakable: the scent of signal salt drives lupar by drilled reflex to their objective.

This *Rally* weapon only affects non-NBC lupar. Friendly non-lupar are not affected. It does not affect airborne units.

APPENDIX B - ARMY SPECIAL MISSIONS

This appendix section describes the underlined special missions of the Army of the Ebon Forest.

Exhortation

“... And remember Tiran, when he slept bare on a bed of roses, and he cursed through the night that the roses concealed thorns... but when he awakened it was not on roses, but sunflowers, and he bled not on the flowers, but on his own claws...”

The Waykeeper Judge may target any non-plane unit in his army, including those in Chemical Weapons or outside of his own LOS, to be steeled with a sermon over the radio. A Waykeeper or Waykeeper Judge may then make a moving fire action in the Fire Phase to Rally the target at any range. Friendly luparic units within 3” of the mission target currently going berserk may then roll a 4+ check to Rally as well, chaining the effect similar to Bloodlust.

When my parents were still young our people were carried not in iron carts but on wooden wheels. To enter the woods unprepared was foolish but the roads were always clear. If you went during the day you would be safe but if you lost your way or the sun began to set none would search for you. To be deserted beneath the boughs meant surrendering to death.

You would not see him without need. The flicker of a torch and the glint of steel. Grass-stained robes. Deliverance. He would call you by name despite never having met your gaze. He would not lay hands upon you yet you would feel his steadying grip on the shoulder. He would speak of sweetness and sighs and song and the roaring shadow would still by his very presence. There is nothing under the leaves that would dare disrespect a Judge.

I am told by the young marching ones that the wise men still do this, in what ways they can.

- Luholde Dubost, Clan Elder

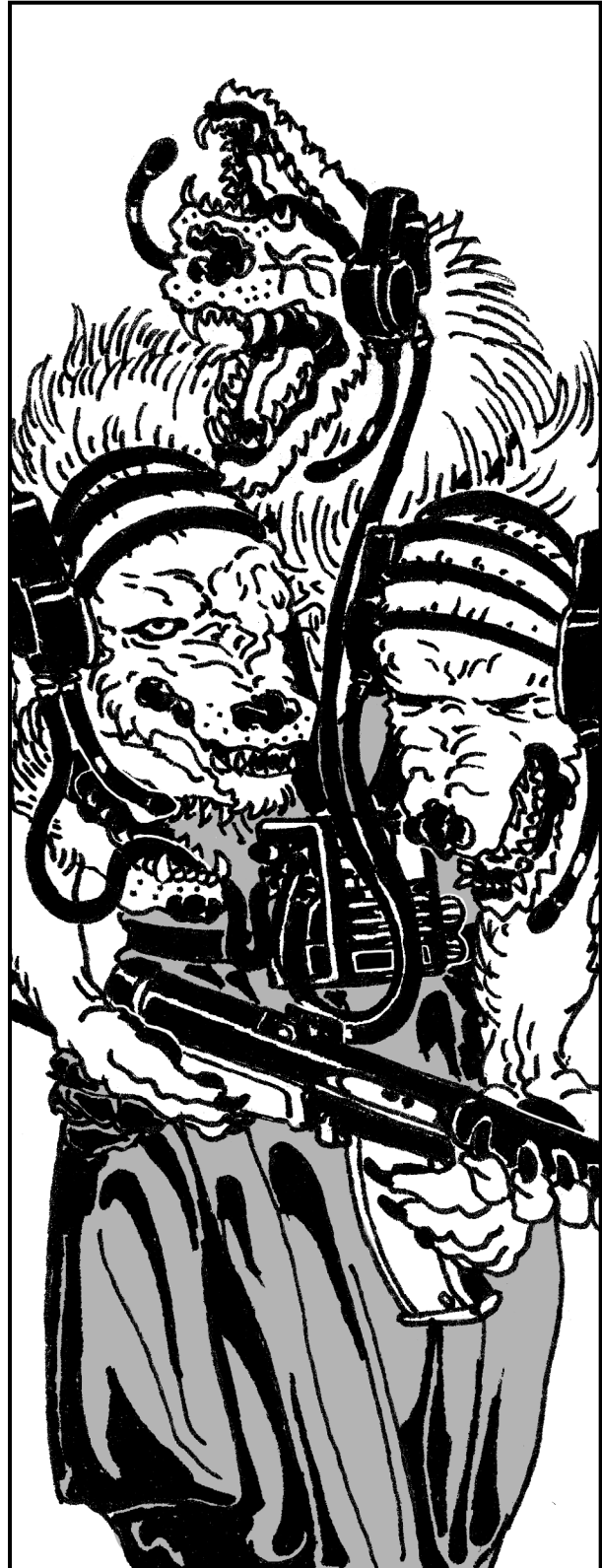

APPENDIX C - BUILDING AN ARMY LIST

This appendix section describes the structure of the Army of the Ebon Forest and provides advice for building an army list.

MILITARY ORGANIZATION

The core of the regular Army of the Ebon Forest, though relatively small, is rigidly drafted to the Regent's specifications, leaving little room for variance in comparison to the other modern militaries of Oid. Frequent frontline scarcities nonetheless lead to irregular organizations and equipment schemes.

The A.E.F. is chronically understrength, and its recruitment affected by local rebellions. The regular army is reliant on territorial troops to sustain their campaigns and uphold homeland security. Some of these territorial units are structured according to the A.E.F. standard; others are household warriors, militia, or various irregular mercenaries and bandits hired on short notice.

When writing an army list, it helps to give it a theme by envisioning what kind of regiment your platoon or company is representing. Luparic regiments are given (in French) a number and basic designation, indicating a notional level of mobility and protection. Here are some labeling guidelines:

d'Infanterie: Infantry regiment, dismounted or with varying levels of logistic support.

Blindée: Mechanized or tank regiment, including tanks and carrier-mobile infantry.

Aéromobile: Airmobile regiment, reliant on helicopters for mobility.

du Roi: Elite infantry and White Gloves: a unit that has earned the Wolf-King's favor.

de l'Intérieur: Technically separate from (but deeply involved in the affairs of) the regular A.E.F., this indicates an Internal Security unit of any kind.

In addition to a descriptive name, most large luparic formations also have a regional name which evokes the grandiosity of Napoleon's Grand Army. Common designations are **Federes** (levies), **Legeres** (light troops), **Chasseurs** (regular infantry), and **Cuirassiers** (armored infantry). **Gardes** indicates an elite unit of ancient pedigree; **Fusiliers** solely refers to White Gloves. Here is an example name:

**23e Régiment d'Infanterie,
"Federes de Fauchillon"**

ARMY LIST COMPOSITION

A typical luparic army list relies on heavy artillery or air support to soften the enemy lines, before overwhelming them with large numbers of mobile, ferocious infantry.

For lower-tier formations, multi-purpose infantry weapons teams and subalterns ensure that your infantry assaults are coordinated, and well-protected. Guided Missile Teams particularly help clear open ground that your infantry might otherwise struggle to cross.

For higher-tier formations, vehicles and helicopters are the hammer to your infantry's anvil, and expensive, upgunned infantry transports help your infantry reach their targets alive. Waykeepers prevent your units from going berserk when it is inopportune.

Indirect fire is the most vital component of the army's ground forces besides the infantry. Cherries are extremely cost-effective and can be used to pin enemy troops and threaten powerful tanks that the A.E.F. has difficulty matching in a head-on fight.

It is good practice to begin by buying some key units which embody core aspects of your regiment's doctrine, then use the remaining points to round out its general capabilities.

SUB-UNIT NAMES

The fundamental sub-unit in a luparic formation is the “groupe”, or group, varying in actual size depending on its parent force’s role. Groupes are ordinally numbered:

- 1er Groupe**
- 2e Groupe**
- 3e Groupe**
- 4e Groupe**

Special-purpose attaches may be given a numberless descriptive name in the fashion of an early 19th century army:

Sous-Groupement de Mortier Legere

1er Groupe traditionally contains the HQ and reserve elements; the remaining groupes constitute line troops and support weapons. Typically a company contains four groupes (a “square” organization), although manpower shortages often dictate fewer sub-units. Support elements are typically embedded directly into their respective groupes rather than being segregated into their own groupe.

CALLSIGNS

When deploying the units of an army list as blinds, it is useful to give each blind a snappy callsign. While it is practical to assign callsigns methodically (“1-1”, “1-2”, “2-1”, etc.), illustrative names are far more entertaining and memorable.

The lupar are a superstitious race, and their sense of reverent mystery may never be fully extinguished by modern skepticism. Their callsigns should allude to ancient European folklore, taking names of famous heroes or monsters. Fighting vehicle names should be appropriately fearsome, perhaps taking inspiration from the epithets of pre-colonial Native Americans. Wizeden Chasseurs may be callsigned “Teutatis”; a chieftain’s transport dubbed the “Holy Oak”; a fearsome helicopter may be the “Banshee”.

OFFICERS & NAMES

Choose one TACOM in your army list—that’s you. Whether an A.E.F. officer or an irregular leader of men, you are no mere commander. Your authority is almost subconscious; though your manifold enemies might outnumber and outgun you, they lack your fighting spirit.

The names of the Ebon Forest are a pastiche of Celtic influences spanning all across the phases of European history from Revolutionary France to pre-Roman Britain. Sounds borrowed from Gaulish, Gaelic, Pictish, and Welsh indicate tribal crudeness, while those from the *langues d’oil* carry the refinement of civilization. Some Luparic minorities may also take smatterings from Finnish, Estonian, or other Baltic languages. Names from the easterly, historically Federal-sympathizing prefectures may have an American English twang.

As with callsigns, never neglect to give yourself a nickname. Consider this archetypal name for a commander of elite infantry:

Capitaine Ceinwen “Split-tooth” Marais

EXAMPLE ARMY LISTS

The following pages have generic example army lists which embody the tenets of conventional luparic doctrine at the 100, 200, 300, and 400 point brackets. Use these as practice lists or points of comparison for creating army lists of your own.

These army lists do not come with suggested regiment names or callsigns, as you are encouraged to come up with your own. These lists also do not make use of dummies, planes, or most support cards, as it is not recommended to use these “advanced” units until a player has the ropes of the game.

**A.E.F. REINFORCED INF. PLATOON
EXAMPLE - 100 PTS, 3 COMMAND**

1er Groupe - Headquarters

Company Chief - *0 pts (TACOM)*
Chasseurs - *10 pts*

2e Groupe - Recoilless Rifle

Chasseurs - *10 pts*
Recoilless Rifle Team - *15 pts*

3e Groupe - Anti-Tank

Subaltern Team - *10 pts*
Chasseurs - *10 pts*
Guided Missile Team - *20 pts*

4e Groupe - Mortar

Chasseurs - *10 pts*
Hima Team - *15 pts*

* [E] - Embarked | [D] - Desanting | [T] - Towed
All written tows/infantry mountings are strictly advisory.

At 100 points, luparic lists may leverage their factional superiority in infantry at minimal risk to their anti-armor capabilities. This dismounted infantry platoon is numerous, diverse in weapons teams, and perfectly optimized to make full use of its limited command tokens by the inclusion of a Subaltern Team for brigade-moving squads independent of the TACOM.

Note the relative versatility of the luparic “counter” weapons teams compared to other factions: the Recoilless Rifle carries canister shot for improved anti-infantry use, the Guided Missile is both anti-tank and anti-air, and the Hima also provides short-ranged AT like an RPG.

Lack of transportation means that this list is slow-going despite command token efficiency. Be careful when crossing open spaces, and guard your long-ranged assets wisely.

This list cannot afford a resupply vehicle, so ammo is precious.

Chasseurs may be replaced with Territorials, thus opening 20 points for a tracked vehicle like a Saucer or Veldjen.

**A.E.F. REINFORCED MECH. PLATOON
EXAMPLE - 200 PTS, 6 COMMAND**

1er Groupe - Headquarters

VBD-1 “Tanner” - *10 pts*
- [E] Company Chief - *0 pts (TACOM)*
- [E] Waykeepers - *15 pts*
- [D] Made-to-Orders - *10 pts*

2e Groupe - Infantry

VBD-1 “Tanner” - *10 pts*
- [E] Chasseurs - *10 pts*
- [E] Machine Gun Team - *10 pts*
- [D] Made-to-Orders - *10 pts*

3e Groupe - Infantry

VBD-1 “Tanner” - *10 pts*
- [E] Chasseurs - *10 pts*
- [E] Machine Gun Team - *10 pts*
- [D] Made-to-Orders - *10 pts*

4e Groupe - Fire Support

VBD-1B “Tanner-R” - *15 pts*
- [E] Guided Missile Team - *20 pts*
- [D] Chasseurs - *10 pts*
CdS-F1 “Kennel” - *10 pts*
- [E] Hima Team - *15 pts (x2)*
- [D] Company Chief - *0 pts (TACOM)*

* [E] - Embarked | [D] - Desanting | [T] - Towed
All written tows/infantry mountings are strictly advisory.

At 200 points, luparic lists can field full-size, mechanized platoons without any loss of manpower. HMGs provide cover for Chasseurs and deny airspace, Waykeepers improve unit cohesion, and the Kennel carrying Hima Teams permits sustained suppressive fire as well as ample smoke and signal salts, two keystones of infantry support.

However, this list lacks a howitzer or a main battle tank, meaning that it will have to rely on encirclement to destroy heavy vehicles. Made-to-Orders should be used to clear the way of infantry in front of your Chasseurs.

This list’s Made-to-Orders may be dropped to upgrade the Tanners to Rawhides or bring extra infantry weapons, though this will force some infantry to desant.

**A.E.F. ASSAULT COMPANY
EXAMPLE - 300 PTS, 11 COMMAND**

1er Groupe - Headquarters

- VBD-2 "Rawhide" - *20 pts*
- [E] Company Chief - *0 pts (TACOM)*
- [E] Waykeeper Judge - *20 pts (TACOM)*
- CdS-F1 "Kennel" - *10 pts*
- [E] Guided Missile Team - *20 pts*
- Char 30 "Veldjen" - *20 pts*

2e Groupe - Reconnaissance

- VBD-2 "Rawhide" - *20 pts*
- [D] White Gloves - *20 pts*
- [E] Company Chief - *0 pts (TACOM)*
- VBD-U "Denmother" - *5 pts*
- [E] Bounders - *20 pts*
- VBD-U "Denmother" - *5 pts*
- [E] Hima Team - *15 pts*

3e Groupe - Infantry

- VBD-1 "Tanner" - *10 pts*
- [E] Subaltern Team - *10 pts*
- [E] Chasseurs - *10 pts*
- VBD-U "Denmother" - *5 pts*
- [E] Machine Gun Team - *10 pts*
- VBD-U "Denmother" - *5 pts*
- [E] Hima Team - *15 pts*

4e Groupe - Infantry

- VBD-1 "Tanner" - *10 pts*
- [E] Chasseurs - *10 pts*
- VBD-U "Denmother" - *5 pts*
- [E] Recoilless Rifle Team - *15 pts*
- VBD-U "Denmother" - *5 pts*
- [E] Hima Team - *15 pts*

* [E] - Embarked | [D] - Desanting | [T] - Towed
All written tows/infantry mountings are strictly advisory.

At 300 points, armored weapons platoons and elite infantry are highly affordable. This company favors speed, so mobile weapons teams supplant desanting infantry as the maneuver element. Bounders and White Gloves provide spotting and pressure at range, while armored units in the HQ function as a reserve force for a climactic breakthrough. Subalterns and a large command pool enable reactive play.

**A.E.F. ARMORED INFANTRY COMPANY
EXAMPLE - 400 PTS, 13 COMMAND**

1er Groupe - Armor

- VBD-3 "Motte" - *20 pts*
- [E] I. S. Escort - *15 pts (TACOM)*
- VBD-2 "Rawhide" - *20 pts*
- [E] Internal Security - *20 pts*
- Char 38 "Borvo" - *40 pts*
- [D] Internal Security - *20 pts*

2e Groupe - Infantry

- VBD-1 "Tanner" - *10 pts*
- [E] Company Chief - *0 pts (TACOM)*
- [E] Chasseurs - *10 pts*
- VBD-1 "Tanner" - *10 pts*
- [E] Subaltern Team - *10 pts*
- [E] Chasseurs - *10 pts*
- Char 30 "Borvo" - *40 pts*
- [D] Chasseurs - *10 pts*

3e Groupe - LAAD

- CdS-36 "Broomcloud" - *25 pts*
- [D] Guided Missile Team - *20 pts*
- [D] Company Chief - *0 pts (TACOM)*
- CdS-36 "Broomcloud" - *25 pts*
- [D] Guided Missile Team - *20 pts*

4e Groupe - Artillery

- CdS-F1 "Kennel" - *10 pts*
- [T] DAG-16 "Cherry" - *25 pts*
- [E] Company Chief - *0 pts (TACOM)*
- CdS-F1 "Kennel" - *10 pts*
- [T] DAG-16 "Cherry" - *25 pts*
- [E] Territorials - *5 pts*

* [E] - Embarked | [D] - Desanting | [T] - Towed
All written tows/infantry mountings are strictly advisory.

At 400 points, a luparic list can accommodate versatile, high-tier unit compositions. This mixed-purpose armored infantry company includes some of the A.E.F.'s best, from heavily armored Internal Security to Broomcloud anti-air guns and Cherry howitzers.

Listbuilding is most fluid at 400 points; for example, the Internal Security could be completely replaced by White Gloves acting as observers for the Cherries, or the Cherries could be replaced by Auroras.

APPENDIX D - QUICK UNIT REFERENCE

This appendix section includes all unit cards from the main chapters.

TACOMS

COMPANY CHIEF - 0 pts
COMMAND TEAM

Inf, H1, S24", M5", Q4, T1+/1/1, C3
Bloodlust, Brigade (4, 8"), Infiltrator, Sense (6")

Mle. 38 .30 LMG
All, R10", A4+/5+, S1/1+, D2,
Small Arm

Mle. 44 3.5-inch RPG
Inf/Vec, R8", A4+/6+, S9/1+, D1,
Ammo 2, *Shaped Charge, Small Arm, Slow Round*

OtPv. 9 30-inch Machete
Inf, R0", A1+/1+, S1/1, D2, *Melee*

Stimulant-Laced Bomb, "Signal Salt"
Gnd, R6", A++/+++, D1, Ammo 1,
Light Indirect (0), Radius (3"), Rally (Salt), Small Arm

INTERNAL SECURITY ESCORT - 15 pts
COMMAND SHOCK SQUAD

Inf (S), H1, S16", M4", Q5, T2/1+/1+, C4
Assault Specialist, Brigade (3, 4"), NBC

FdcL 63 4-gauge Shotgun
Inf/Vec, R6", *Small Arm*
→ **4-gauge Houndshot**
A4+/4+, S1/1+, D3
→ **4-gauge Rifled Slug**
A3+/3+, S2/3, D1

OtDs. 13 Tactical Breaching Charge
Vec, R0", A1+/1+, S12/12, D1,
Ammo 2, *Melee*

OtPv. 9 30-inch Machete
Inf, R0", A1+/1+, S1/1, D2, *Melee*

Stimulant-Laced Filter, "Signal Snuff"
Inf*, R0", A++/+++, D1, Ammo 1,
Discreet, Rally
*May only target self

WAYKEEPER JUDGE - 20 pts
RELIGIOUS LEADER

Inf, H1, S24", M4", Q5, T1/1/1, C5
Amphibious, Brigade (3, 12"), Guidance (12"), Infiltrator, Sense (8")

While this unit is alive, no unit in this army can willingly go berserk. Only Judges may call Exhortation support missions.

Mle. 32 .30 Self-loading Rifle
All, R8", A3+/4+, S1/1+, D1,
Multi-Gun, Small Arm

Teeth & Claws
Inf, R0", A1+/1+, S1/1, D1, *Melee*

Stimulant-Laced Bomb, "Signal Salt"
Gnd, R6", A++/+++, D1, Ammo 1,
Light Indirect (0), Radius (3"), Rally (Salt), Small Arm

FEDERAL STATES-ARMY - DREKFORT M.D.C.

INFANTRY - LINE SQUADS

TERRITORIALS - 5 pts
MILITIA SQUAD

Inf (S), H1, S24", M5", Q2, T1/1-/1-
Amphibious, Bloodlust, Infiltrator, Sense (6")

Mle. 32 .30 Self-loading Rifle
All, R8", A4+/4+, S1/1+, D1,
Small Arm

OtPv. 9 30-inch Machete
Inf, R0", A1+/1+, S1/1, D2, *Melee*

FEDERAL STATES-ARMY - DREKFORT M.D.C.

CHASSEURS - 10 pts

LINE SQUAD

Inf (S), H1, S24", M5", Q2, T1+/1/1

Bloodlust, Infiltrator, Sense (6")

Mle. 38 .30 LMG

All, R10", A4+/5+, S1/1+, D2,
Small Arm

Mle. 44 3.5-inch RPG

Inf/Vec, R8", A4+/6+, S9/1+, D1,
Ammo 4, *Shaped Charge, Small Arm, Slow Round*

OtPv. 9 30-inch Machete

Inf, R0", A1+/1+, S1/1, D2, *Melee*

FEDERAL STATES-ARMY - DREKFORT M.D.C.

INTERNAL SECURITY - 20 pts

ELITE SHOCK SQUAD

Inf (S), H1, S16", M4", Q4, T2/1+/1+

Assault Specialist, NBC

FdcL 63 4-gauge Shotgun

Inf/Vec, R6", *Small Arm*

→ **4-gauge Houndshot**

A4+/4+, S1/1+, D3

→ **4-gauge Rifled Slug**

A3+/3+, S2/3, D1

OtDs. 13 Tactical Breaching Charge

Vec, R0", A1+/1+, S12/12, D1,
Ammo 2, *Melee*

OtPv. 9 30-inch Machete

Inf, R0", A1+/1+, S1/1, D2, *Melee*

Stimulant-Laced Filter, "Signal Snuff"

Inf*, R0", A++/++, D1, Ammo 1,
Discreet, Rally

*May only target self.

FEDERAL STATES-ARMY - DREKFORT M.D.C.

WHITE GLOVES - 20 pts

ELITE LINE SQUAD

Inf (S), H1, S24", M5", Q4, T1+/1/1

Bloodlust, Fearless, Sense (6")

Mle. 52F .30 Automatic Rifle

All, R8", A4+/4+, S1/1+, D2,
Small Arm

Lacra 3.5-inch Shouldered R. R.

A3+/5+, D1, Ammo 4, *Small Arm*

→ **3.5-inch Rocket-Assisted Sabot**

Vec, R20", S8/12

→ **3.5-inch HEAT**

Inf/Vec, R16", S9/1+, *Shaped Charge, Slow Round*

→ **3.5-inch Incendiary**

Inf/Vec, R16", S1+/1+,
Ignore Cover (2), Rear Attack, Slow Round

Mle. 7 Laser Designator

All, R40", A++/xx,
Designator, Discreet

Mle. 313 26-inch Side Saber

Inf, R0", A1+/1+, S1+/1+, D2, *Melee*

FEDERAL STATES-ARMY - DREKFORT M.D.C.

INFANTRY - WEAPON TEAMS

MACHINE GUN TEAM - 10 pts

ANTI-PERSONNEL/MATERIEL TEAM

Inf, H1, S24", M5", Q2, T1/1-/1-

Bloodlust, Infiltrator, Sense (6")

Mle. 32 .30 Self-loading Rifle

All, R8", A4+/4+, S1/1+, D1,
Small Arm

Mtl. 19 .50 HMG

All, R20", A4+/6+, S2/3, D2,
Defensive CC

FEDERAL STATES-ARMY - DREKFORT M.D.C.

HIMA TEAM - 15 pts
ANTI-PERSONNEL/TANK TEAM

Inf, H1, S24", M5", Q2, T1/1-/1-
Bloodlust, Sense (6")

Mle. 32 .30 Self-loading Rifle
All, R8", A4+/4+, S1/1+, D1,
Small Arm

Lacra-76 "Hima" 3-inch Launcher
Ammo 4

→ **3-inch Frag**
Gnd, R32", A4+/xx, S[D3], D1,
*Air-Filling, Light Indirect (2),
No CC, Radius (2")*

→ **3-inch HEAT**
Inf/Vec, R8", A4+/xx, S8/1+, D1,
Shaped Charge, Slow Round

→ **3-inch Smoke**
Gnd, R32", A++/xx, D2,
Light Indirect (2), No CC, Smoke (3")

→ **3-inch Signal Salt**
Gnd, R32", A++/xx, D1,
*Light Indirect (2), No CC, Radius (3"),
Rally (Salt)*

FEDERAL STATES-ARMY - DREKFORT M.D.C.

RECOILLESS RIFLE TEAM - 15 pts
GENERAL-PURPOSE TEAM

Inf, H1, S24", M5", Q2, T1/1-/1-
Bloodlust, Infiltrator, Sense (6")

Mle. 32 .30 Self-loading Rifle
All, R8", A4+/4+, S1/1+, D1,
Small Arm

TAP 20 3-inch Recoilless Rifle
Ammo 4

→ **3-inch HEAT**
Inf/Vec, R24", A4+/6+, S8/1+, D1,
*No CC (Inf.), Shaped Charge,
Slow Round*

→ **3-inch Canister**
Inf/Vec, R12", A4+/6+, S1/1+, D3,
Defensive CC (Inf.)

→ **3-inch Smoke**
Gnd, R24", A++/++, D1, No CC,
Smoke (3")

FEDERAL STATES-ARMY - DREKFORT M.D.C.

GUIDED MISSILE TEAM - 20 pts
ANTI-TANK/AIR TEAM

Inf, H1, S32", M5", Q2, T1/1-/1-
Bloodlust, Sense (6")

Mle. 32 .30 Self-loading Rifle
All, R8", A4+/4+, S1/1+, D1,
Small Arm

SD84 4.7-inch Missile Launcher
S15/2, D1, Ammo 4,
*Guided Missile (2), No CC,
Shaped Charge*

→ **ATGM Guidance Mode**
Vec, R6-60", A3+/xx

→ **MANPADS Guidance Mode**
Air, R60", A4+/xx

FEDERAL STATES-ARMY - DREKFORT M.D.C.

INFANTRY - SPECIAL

SUBALTERN TEAM - 10 pts
 JUNIOR COMMAND TEAM

Inf, H1, S24", M5", Q4, T1/1-/1-
Bloodlust, Brigade (2, 4"), Infiltrator,
Sense (6")

Mle. 32 .30 Self-loading Rifle
 All, R8", A4+/4+, S1/1+, D1,
Small Arm

OtPv. 9 30-inch Machete
 Inf, R0", A1+/1+, S1/1, D2, *Melee*

MdG. 341 Smoke Bomb
 Gnd, R6", A++/+++, D1, Ammo 1,
Light Indirect (0), Small Arm,
Smoke (2")

FEDERAL STATES-ARMY - DREKFORT M.D.C.

MADE-TO-ORDERS - 10 pts
 BERSERKER SQUAD

Inf (S), H1, S24", M5", Q6, T1+/1+/1+
Amphibious, Bloodlust, Tow (2), Sense (6")

*If depleted, loses its depletion token at the end
of the round after winning a close combat.*

Mutated Teeth & Claws
 Inf/Vec, R0", A1+/1+, S1+/1+, D3,
Melee

FEDERAL STATES-ARMY - DREKFORT M.D.C.

WAYKEEPERS - 15 pts

RELIGIOUS INSTRUCTORS

Inf (S), H1, S24", M5", Q4, T1/1/1
Amphibious, Guidance (12"), Infiltrator,
Sense (8")

Mle. 32 .30 Self-loading Rifle
 All, R8", A3+/4+, S1/1+, D1,
Multi-Gun, Small Arm

Teeth & Claws
 Inf, R0", A1+/1+, S1/1, D1, *Melee*

Stimulant-Laced Bomb, "Signal Salt"
 Gnd, R6", A++/+++, D1, Ammo 1,
Light Indirect (0), Radius (3"),
Rally (Salt), Small Arm

FEDERAL STATES-ARMY - DREKFORT M.D.C.

BOUNDERS - 20 pts

ANTI-MATERIEL/SNIPER TEAM

Inf, H1, S32", M5", Q2, T1/1-/1-
Amphibious, Bloodlust, Infiltrator, Sense (6")

Mle. 32 .30 Self-loading Rifle
 All, R8", A4+/4+, S1/1+, D1,
Small Arm

APX-25 1-inch Anti-Tank Rifle
 All, R32", A3+/xx, S4/6, D1,
 Ammo 4, *No CC (Inf.), Scoped*

FEDERAL STATES-ARMY - DREKFORT M.D.C.

VEHICLES - LOGISTICS

CdS-F1 "KENNEL" - 10 pts
 IMPROVISED GUN TRUCK

Vec (W), H2, S16", M8", Q2, T2/2/1
PC (2, Rear), Resupply (6), Tow (3)

Mtl. 19 .50 HMG
 All, R20", A4+/6+, S2/3, D2, *Turret*

FEDERAL STATES-ARMY - DREKFORT M.D.C.

VEHICLES - PERSONNEL CARRIERS

VBD-U "DENMOTHER" - 5 pts
 UNIVERSAL CARRIER

Vec, H1, S16", M8", Q2, T3/2/1+
 PC (1, Any)

This unit uses a 40x40mm base. Cannot have embarked units and desants at the same time. Embarked units can fire any one non-Melee weapon as if it were a Small Arm and are identified with the vehicle. Units embarked may spot and be spotted by Sense.

Lenus Automatic .45, driver's issue
 All, R2", A4+/4+, S1+/1+, D1,
 Small Arm

VBD-1 "TANNER" - 10 pts
 ARMORED PERSONNEL CARRIER

Vec, H2, S32", M8", Q2, T4/4/3
 Amphibious, NBC, PC (3, Rear)

Mtl. 19 .50 HMG
 All, R20", A4+/6+, S2/3, D2, Turret

FEDERAL STATES-ARMY - DREKFORT M.D.C.

VBD-2 "RAWHIDE" - 20 pts
 INFANTRY FIGHTING VEHICLE

Vec, H2, S32", M8", Q2, T5/5/4
 Active Protection (1), NBC, PC (2, Rear)

Mtl. 19 .50 HMG
 All, R20", A4+/5+, S2/3, D2, Turret

APX-30 1-inch Autocannon
 All, R32", A4+/5+, S4/6, D2,
 Ammo 4, No CC (Inf.), Turret

Mle. 254 2.3-inch Smoke Launchers
 Gnd, R0", A++/+++, D1, Ammo 1,
 Light Indirect (0), No CC, Smoke (2")

FEDERAL STATES-ARMY - DREKFORT M.D.C.

VBD-3 "MOTTE" - 20 pts
 ARMORED PERSONNEL CARRIER

Vec, H2, S32", M8", Q3, T16/10/6
 NBC, PC (2, Rear, Front)

Mle. 38C .30 MG, swivels
 All, R12", A4+/5+, S1/1+, D2, Turret

Mtl. 19 .50 HMG
 All, R20", A4+/5+, S2/3, D2,
 Multi-Gun

Mle. 254 2.3-inch Smoke Launchers
 Gnd, R0", A++/+++, D1, Ammo 1,
 Light Indirect (0), No CC, Smoke (2")

FEDERAL STATES-ARMY - DREKFORT M.D.C.

VEHICLES - ARMOR

CHAR 30 "VELDJEN" - 20 pts
 MEDIUM TANK

Vec, H2, S32", M8", Q2, T10/6/5
 NBC

Mle. 38C .30 MG
 All, R12", A4+/6+, S1/1+, D2, Turret

SA19 3-inch Gun
 R32", A4+/6+, D1, Ammo 6,
 No CC (Inf.), Slow Round, Turret

→ **3-inch APHE**
 Vec, S8/12

→ **3-inch HE-Frag**
 Inf/Vec, S3/3, Ignore Cover (1)

LF4 Sponson Flamethrower
 Inf/Vec, R8", A3+/3+, S1+/1+, D3,
 Ammo 3, Ignore Cover (2),
 Multi-Gun, Rear Attack

FEDERAL STATES-ARMY - DREKFORT M.D.C.

CHAR 38 "BORVO" - 40 pts

MAIN BATTLE TANK

Vec, H2, S32", M8", Q2, T14/10/6
NBC

Mle. 38C .30 MG

All, R12", A4+/5+, S1/1+, D2,
Thermal Sights, Turret

SA19B 3-inch Dual Guns

A3+/4+, Ammo 6, *Barrage (2),
Thermal Sights, Tracking Anti-Air,
Turret*

→ 3-inch APHE

Vec, R40", S8/12, D1, *No CC (Inf.),
Slow Round*

→ 3-inch HEAT

Inf/Vec, R40", S9/1+, D1,
*No CC (Inf.), Shaped Charge,
Slow Round*

→ 3-inch Canister

All, R20", S1/1+, D3,
Defensive CC (Inf.)

Mle. 254 2.3-inch Smoke Launchers

Gnd, R0", A++/+++, D1, Ammo 1,
*Light Indirect (0), No CC, Smoke (2"),
Turret*

FEDERAL STATES-ARMY - DREKFORT M.D.C.

VEHICLES - FIRE SUPPORT

VBD-1B "TANNER-R" - 15 pts

RECOILLESS RIFLE CARRIER

Vec, H2, S32", M8", Q2, T4/4/3
Amphibious, NBC, PC (1, Rear)

Mle. 32 .30 Self-loading Rifle

All, R8", A4+/4+, S1/1+, D1,
Small Arm

TAP 30 4.2-inch Recoilless Rifle

Ammo 4

→ 4.2-inch HEAT

Inf/Vec, R28", A4+/6+, S12/2, D1,
*No CC (Inf.), Shaped Charge,
Slow Round*

→ 4.2-inch Canister

Inf/Vec, R14", A4+/6+, S1/1+, D4,
Defensive CC (Inf.)

→ 4.2-inch White Phosphorus

Gnd, R28", A4+/6+, S1+/1+, D1,
*Ignore Cover (2), No CC, Rear Attack,
Smoke (3")*

FEDERAL STATES-ARMY - DREKFORT M.D.C.

DAG-8 "BLOSSOM" - 15 pts
TOWED ANTI-TANK GUN

Vec (C), H1, S32", M3", Q2, T2/1/1

Mle. 38 .30 LMG

All, R10", A4+/5+, S1/1+, D2,
Small Arm

DAG-8 3.3-inch Gun

R40", A3+/xx, D1, Ammo 4,
No CC, Thermal Sights

→ **3.3-inch Sabot**

Vec, S12/18

→ **3.3-inch HE-Frag**

Inf/Vec, S3/3, *Ignore Cover (1),
Slow Round*

FEDERAL STATES-ARMY - DREKFORT M.D.C.

CdS-F3 "FORESTER" - 15 pts
ANTI-AIR GUN TRUCK

Vec (W), H2, S16", M8", Q2, T2/2/1
Tow (2)

AMA-2 .60 Dual HMGs

All, R24", A4+/6+, S3/4, D3,
Turret, Tracking Anti-Air

FEDERAL STATES-ARMY - DREKFORT M.D.C.

CdA-25 "SAUCER" - 20 pts
TANK DESTROYER

Vec, H1, S32", M10", Q2, T6/3/2
NBC

Mtl. 19 .50 HMG

All, R20", A4+/6+, S2/3, D2,
Turret

SA25 2.5-inch High Velocity Gun

Vec, R40", A4+/5+, S12/18, D1,
Ammo 6

FEDERAL STATES-ARMY - DREKFORT M.D.C.

DAG-16 "CHERRY" - 25 pts
TOWED HOWITZER

Vec (C), H1, S24", M2", Q2, T1/1-1-

Mle. 32 .30 Self-loading Rifle

All, R8", A4+/4+, S1/1+, D1,
Small Arm

DAG-16 7.8-inch Howitzer

Ammo 3, *No CC*

→ **7.8-inch HEAT**

Inf/Vec, R40", A3+/xx, S16/3, D1,
Shaped Charge, Slow Round

→ **7.8-inch Frag**

Gnd, R∞", A4+/xx, S[D6], D3,
*Air-Filling, Heavy Indirect (3),
Radius (3")*

→ **7.8-inch Canister**

All, R20", A4+/xx, S1/1+, D6,
Radius (2")

→ **7.8-inch Smoke**

Gnd, R∞, A++/xx, D4,
Heavy Indirect (3), Smoke (5")

FEDERAL STATES-ARMY - DREKFORT M.D.C.

CdS-F2 "AURORA" - 30 pts
ROCKET TRUCK

Vec (W), H2, S16", M8", Q2, T2/2/1

Mle. 32 .30 Self-loading Rifle
All, R8", A4+/4+, S1/1+, D1,
Small Arm

Mle. 13 5.2-inch Rocket Rack
Gnd, R12-∞", A4+/5+, S6/6, D2,
Ammo 6, *Air-Filling,*
Ignore Cover (1), Heavy Indirect (2),
No CC, Saturating (6)

FEDERAL STATES-ARMY - DREKFORT M.D.C.

VEHICLES - SPECIAL

VdIM-K "KARVE" - 10 pts
SPEEDBOAT

Vec, H1, S32", M12", Q2, T2/2/1
PC (4, Any), Watercraft

Mtl. 19 .50 HMG
All, R20", A4+/4+, S2/3, D2, *Turret*

FEDERAL STATES-ARMY - DREKFORT M.D.C.

AIRCRAFT - HELICOPTERS

VZ61 "CHARIOTS" - 15 pts
DUCTED FAN PLATFORMS

Air, H1, S24", M18", Q2, T1+/1/1

This unit uses a 40x40mm base and can be depleted as if it were an infantry squad. When landed, unit class counts as Inf (S); it may fire all weapons and enter close combat as if it were infantry. May land in forests and inside of buildings as a squad-sized garrison.

Mle. 38 .30 LMG
All, R10", A4+/5+, S1/1+, D2, *Turret*

Mle. 44 3.5-inch RPG
All, R8", A4+/6+, S9/1+, D1,
Ammo 4, *Shaped Charge,*
Slow Round, Turret

FEDERAL STATES-ARMY - DREKFORT M.D.C.

AES514 "BACKBONE" - 20 pts
HEAVY LIFT HELICOPTER

Air, H2, S32", M24", Q2, T3/2/3
Decoy Protection (2), PC (2, Sides), Tow (10)

Embarked units can fire any one non-Melee weapon as if it were a Small Arm and are identified with the vehicle. Units embarked may spot and be spotted by Sense.

FEDERAL STATES-ARMY - DREKFORT M.D.C.

AES805 "TORNADO" - 30 pts
ATTACK HELICOPTER

Air, H1, S32", M32", Q3, T2/2/2
Decoy Protection (2)

APX-30 1-inch Autocannon

All, R32", A4+/5+, S4/6, D2,
Ammo 4

SD84 4.7-inch Missile Launcher

S15/2, D1, Ammo 2,
Door Gun (Front, Sides),
Guided Missile (2), No CC,
Shaped Charge

→ **ATGM Guidance Mode**

Vec, R6-60", A3+/4+

→ **MANPADS Guidance Mode**

Air, R60", A4+/4+

FEDERAL STATES-ARMY - DREKFORT M.D.C.

VBD SPECIAL "LUGUS" - 25 pts
RECOILLESS RIFLE CARRIER

Vec, H1, S32", M8", Q3, T3/2/1+

This unit uses a 40x40mm base.

Lenus Automatic .45, driver's issue

All, R2", A4+/4+, S1+/1+, D1,
Small Arm

TAP 25 4.2-inch Recoilless Rifle Battery

Ammo 6, *Barrage (6, Point)*

→ **4.2-inch HEAT**

Inf/Vec, R28", A4+/6+, S12/2, D1,
No CC (Inf.), Shaped Charge,
Slow Round

→ **4.2-inch Canister**

Inf/Vec, R14", A4+/6+, S1/1+, D4,
Defensive CC (Inf.)

→ **4.2-inch White Phosphorus**

Gnd, R28", A4+/6+, S1+/1+, D1,
Ignore Cover (2), No CC, Rear Attack,
Smoke (3")

CdA-36 "BROOMCLOUD" - 25 pts
SELF-PROPELLED ANTI-AIR GUN

Vec, H2, S32", M10", Q3, T5/3/1+

Mle. 32 .30 Self-loading Rifle

All, R8", A4+/4+, S1/1+, D1,
Small Arm

APX-40 1.5-inch Autocannon

All, R36", A4+/4+, S5/7, D2,
Ammo 6, *No CC (Inf.),*
Radar Anti-Air, Turret

FEDERAL STATES-ARMY - DREKFORT M.D.C.

AIRCRAFT - PLANES

R-2 "CHIEN DE CHASSE" - 10 pts

OBSERVATION AIRCRAFT

Air (CAS), M10", Q2, T2, E0

Loiter

Does not break designation when it moves.

Designation is broken when the target leaves frontal arc. Counts as E3 in dogfights.

Mtl. 19 .50 HMGs, dual

All, R4", A6+, S2, D2

Mle. 7 Laser Designator

All, R40", A++, D1, *Designator*

FEDERAL STATES-ARMY - DREKFORT M.D.C.

AD-48 "FALCONET" - 20 pts

LIGHT ATTACK AIRCRAFT

Air (CAS), M14", Q3, T2, E1

Decoy Protection (2)

Mtl. 19 .50 HMGs, octet

All, R4", A4+, S2, D3, *Radar Anti-Air*

LR-49 2.7-inch HEAT Rocket Pod

Inf/Vec, R6", A4+, S7/1+, D4,
Ammo 2, *Barrage (2), Shaped Charge, Slow Round*

BLG-64 500-lb. HE Cluster Bomb

Gnd, R0", A2+, S4, D2, Ammo 4,
Air-Filling, Rear Attack, Saturating (4)

AD-IV "GROGNARD" - 35 pts

FIGHTER-BOMBER

Air (CAP), M16", Q3, T3, E2

Afterburner, Decoy Protection (2)

APX-50 1.4-inch Revolver Cannon

All, R8", A4+, S5, D3, Ammo 3,
Radar Anti-Air

MA-67 4.7-inch Infrared AAM

Air, R30", A3+, S6, D1, Ammo 2,
Air-Filling, Guided Missile (1), Homing

SD68 8-inch TV-Guided Bomb

Gnd, R40", A3+, S8, D1, Ammo 2,
Air-Filling, Guided Missile (2), Radius (3"), Rear Attack

MD-II "MIST" - 40 pts

AIR SUPERIORITY FIGHTER

Air (CAP), M20", Q4, T3, E3

Afterburner, Decoy Protection (2)

APX-50 1.4-inch Revolver Cannon

All, R8", A3+, S5, D3, Ammo 3,
Radar Anti-Air

MA-67B 4.7-inch Infrared AAM

Air, R36", A3+, S6, D1, Ammo 2,
Air-Filling, Guided Missile (1), Homing

MA-62 7.9-inch Semi-Active AAM

Air, R60", A4+, S8, D1, Ammo 4,
Barrage (2, Point), Guided Missile (1), No CC

FEDERAL STATES-ARMY - DREKFORT M.D.C.



శ్రీ గాంధీ జయంతి సందర్భంగా
 ప్రతి భారతీయునినీ

శ్రీ గాంధీ జయంతి సందర్భంగా
 ప్రతి భారతీయునినీ

శ్రీ గాంధీ జయంతి సందర్భంగా
 ప్రతి భారతీయునినీ

శ్రీ గాంధీ జయంతి సందర్భంగా
 ప్రతి భారతీయునినీ

APPENDIX E - PAINTING GUIDE

This appendix section provides full-color references for painting your Ebon Forest miniatures.

Gun Body

Coif

Stock & Grip

Fatigues

Belt

Hilt & Buttons

Socks

GUN METAL
#515151

WOOD FURNITURE
#9C5E27

LUPARIC FELDGRAU
#737657

DARK BLACK LEATHER
#181910

FOOL'S GOLD
#D5B737

FAITH RED
#A22C00

Common Headgear

INFANTRY NOTES

Lupar can exhibit any variety of natural wolf-pelt scheme and lupine eye colors. Coats are almost always agouti with at least two tones.

The issued coif, soft garrison cap, and socks are red. Red is the color of faith for lupar: their eyes cannot distinguish it, but they know it's there.

Rank insignia are red and marked by solid color on the cuffs. Lower enlisted men do not typically wear any insignia. Officers wear gold braiding.

Older uniforms (in green, beige, or black without camouflage) are occasionally still worn by territorial units and clan militias.

Commissioned officers are distinguished by their crested helmets and black cockades. While the former is almost always worn in the field, the latter is not due to its tendency to draw fire.

The wearing of soft caps into combat is an informal tradition of the A.E.F.'s artillery branch.

Common Pelt Colors

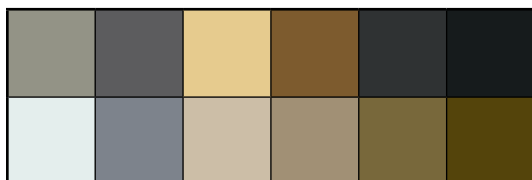

Secondary

Primary

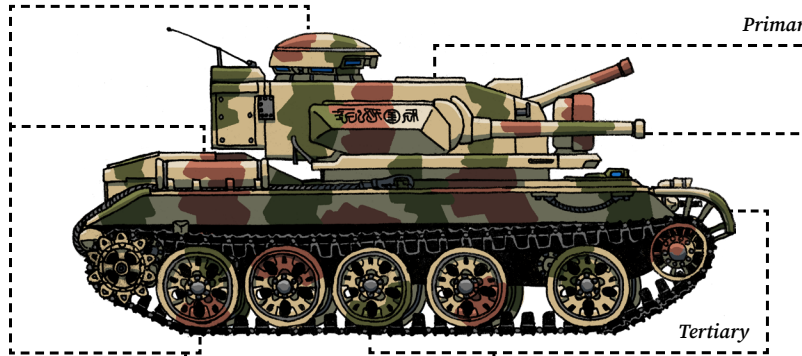

Ebon Roundel

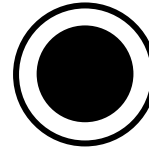

Hameçon



Hameçon (Alternative)

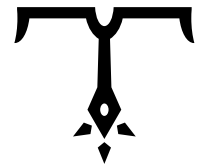

RUDDY SPOCH
#884F40

GREEN SPOCH
#545732

TAN DRAB
#CDB587

Secondary

Tertiary

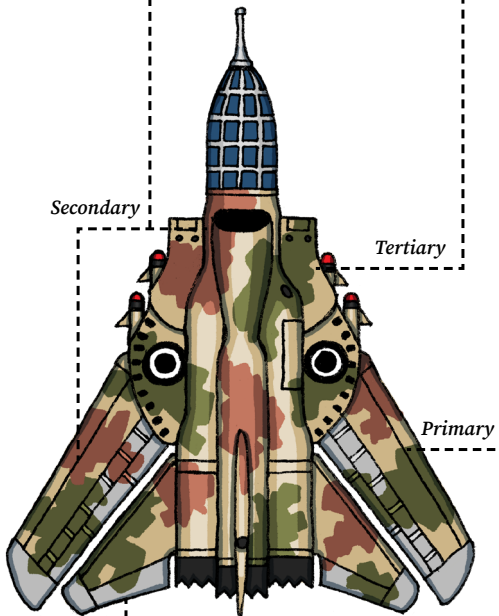

FACTORY SILVER
#BBBBBB

"Hameçonites" Roundel



Countershade

FLYING CIRCUS RED
#ED1C24

Primary

BEER MUSTARD
#F2F35C

Secondary

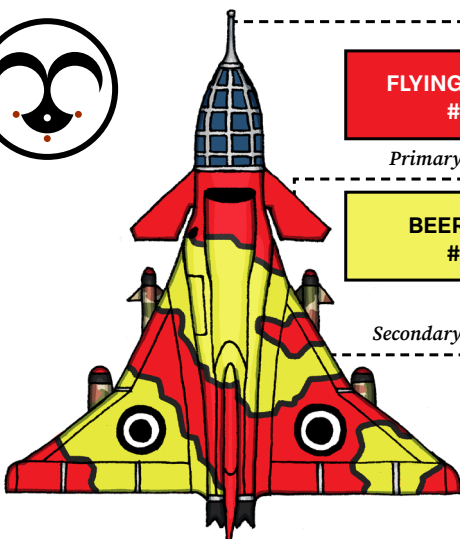

ARMOR NOTES

Regular A.E.F. vehicles are painted to a single standard camouflage scheme. In winter the colors may be modified with whites and grays. Local flora, camo netting, crude scrawls or animal skulls are often added in the field.

Vehicles fielded by irregular units are often salvaged (or simply stolen), bearing the scars of battle, and may be repainted in solid gray or beige.

Vehicles are usually marked with the Ebon Forest roundel with or without a white filling. Clan militias typically use familial symbols or personal insignia. Some elite royal regiments are granted the use of the *hameçon*, a symbol of the Wolf-King. The symbol has many variants.

AIRCRAFT NOTES

Aircraft follow the same scheme as ground vehicles, with gray counter-shaded bellies. The very same symbols used on ground vehicles are applied to aircraft.

Grognards are uniquely painted in personalized, high-contrast "flying circus" schemes according to the whims of their pilots. The roundel is always painted to standard, however.

Decorated soldiers of all kinds, but especially pilots, may fly an altered *hameçonites*, which is accented with the red of faith.





While my mother still drew breath I considered the village I called home to be one of fine fortune. There was a learned man whose circuits through Dubost land would routinely guide him around the thickets about our clearing, then straight through the township proper. Barred doors would unbolt and even the chieftain's guard or the chicken-man's son would step aside to give him way. At times his legs, twisted as they were, would fail him and he would need to use arms to steady himself, trailing his gnarled foot behind him and loping forward with slow sighs. No aid was rendered or requested, and the wise man would hold his heads high, two sets of eyes peering from beneath the hood at both shoulders, glancing through each alleyway and window. Any man whose need eclipsed his duty would put down his tools or his weapons to take after the wizened one and he would not be blamed for this. As the waykeeper left the houses those seeking his guidance would trickle out after him and disappear into the copse past the village gate.

He would lead this following through the twisting tunnels of bark and bristles to emerge at a blockfield that marked what was once a great riverbed. When the darkness of the canopy faded and the waykeeper's skin was kissed by the sun he disrobed to the waist and lay himself bare. He would stretch his many arms to the sky and splay his fingers and crane his necks and close his eyes as if beckoning his attendants to gaze upon him. If you dared to indulge his provocation you would see plainly his pride and his shame; you would see plainly the price paid for perspicacity. Every limb crooked, his form crossed with scars, his breathing ragged, shoulders split and knitted back together to support the heft of four heads. If you followed the lines traced through his pelt you would trail them up the length of his broken body until you found the ragged stump of a ruined throat.

Once the field was reached he would no longer speak to us. Instead he carried with him the weight of our words. Before a single breath was uttered each man would choose his stone. Some would fill baskets; others would lash theirs to their back. More often than not it would simply be carried over the shoulders. No matter the bearing each man's burden threatened to break him. We suffered. When a man carries weight with him he does not feel weak. When a man is burdened he is free. Lungs burning before we even began, the venerable one directed us to march. Dubost land lies in the shadow of a lone mountain, and when the leaves are thin enough you can see it stand in silent judgment. That is how we walked, with the ancients afore and behind us. Eyes fixed on the mountain ahead, branch and bramble trampled bloody underfoot, we would slowly begin to speak.

Each man would take his turn and he would tell of his troubles. He would tell of the things he could do but did not; he would tell of the things he should not do but did. He would tell of the things he could not stop himself from doing and whenever he would doubt himself he would feel the stone strain his muscles and he would remember that he is not weak. The waykeeper and the mountain would listen to our words and take them from us. When we reached the crest we would stop only to gather and watch as the wise one would bite his tongues and open his palms and return our trespasses to the darkness of the forest. In that moment to hold a stone was to hold spring in your hands. Carrying the weight on your shoulders seemed the simplest task in the world. Hearts and heads lightened, we would follow the waykeeper back to the blockfield, and each man would place his stone right back where he found it—in case his sons needed it someday.

My mother went in her sleep many moons ago. Electric lights burn in each alleyway and window. The old one no longer comes to our village. We break up the stones and use them to bury the boys who come home from the Regent's wars in an ebonwood box.

- Luholde Dubost, Clan Elder



By Order of the Ministry of Defense:

DANEEL DAAF

*General of the Air,
General Staff of the Federal States-Army*

JOHANNES VEENEMAN

*General of the Army,
General Staff of the Federal States-Army*

Signatories:

BRIGGS CARTOGRAAF

*Brigadier General,
Main Diagrammatical Directorate*

JAAN SCHRIMM

*Brigadier General,
Main Diagrammatical Directorate*

MARLIJN MUNTTHEE

*Brigadier General,
Main Rocket & Artillery Directorate*

KENNET PLUUSMAN

*Brigadier General,
Main Topographical Directorate*

MANFIELD GARFIELD

*Brigadier General,
Main Topographical Directorate*

ITTIE BEBSON

*Brigadier General,
Main Topographical Directorate*

JAKUB DROOK

*Major General,
Main Luparic Readiness Directorate*

MAXIMILLIAAN BROOD

*Lieutenant General,
Main Publishing Directorate*

DIJKEN EIKKSEN

*Major General,
Main Tactics & Doctrine Directorate*

DISTRIBUTION:

Active Army, Whitewater Guard, Ready Reserves, Irregular Militia Partnership Program: To be distributed in accordance with DA Form 12-1A, Keystone Knowledge for the Federal Soldier (Qty rqr block no. 174).

Additional copies may be requisitioned from the F.S.-A.-M.T. & D.D. General Publications Center, 1322 Worstenrij, Brunbok, Vykeland-and-Deire 21450.

